

# MITSUBISHI

## A950GOT/A951GOT/A953GOT/A956GOT

### User's Manual

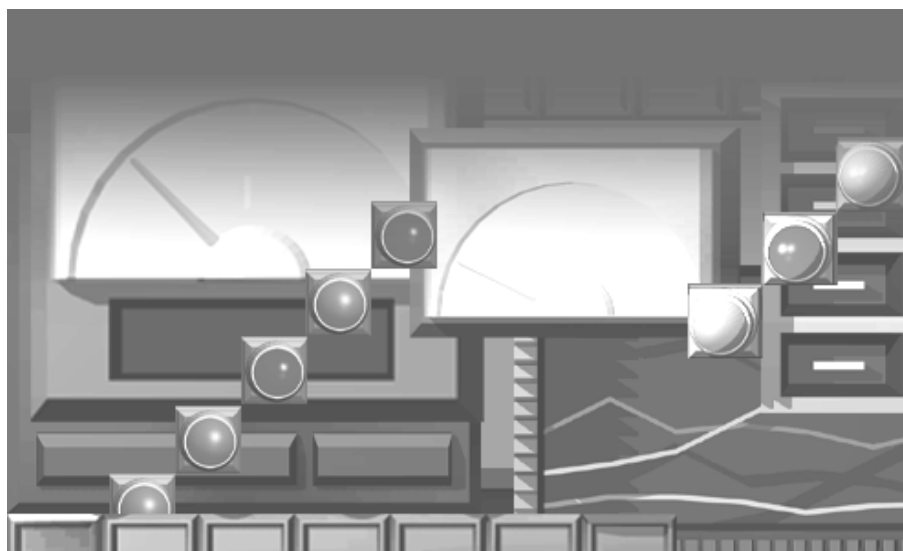

*Graphic Operation Terminal*  
**900**  
series



MITSUBISHI Graphic Operation Terminal

A950GOT-TBD/SBD/LBD(-M3)  
A951GOT-QTBD/QSBD/QLBD(-M3)  
A951GOT-TBD/SBD/LBD(-M3)  
A953GOT-TBD/SBD/LBD(-M3)  
A956GOT-TBD/SBD/LBD(-M3)  
A956WGOT-TBD

# • SAFETY PRECAUTIONS •

(Always read these instructions before using this equipment.)

Before using this product, please read this manual and the relevant manuals introduced in this manual carefully and pay full attention to safety to handle the product correctly.

The instructions given in this manual are concerned with this product. For the safety instructions of the programmable controller system, please read the CPU module user's manual.

In this manual, the safety instructions are ranked as "DANGER" and "CAUTION".



Indicates that incorrect handling may cause hazardous conditions, resulting in death or severe injury.



Indicates that incorrect handling may cause hazardous conditions, resulting in medium or slight personal injury or physical damage.

Note that the  CAUTION level may lead to a serious consequence according to the circumstances. Always follow the instructions of both levels because they are important to personal safety.

Please save this manual to make it accessible when required and always forward it to the end user.

## [Design Precautions]

### DANGER

- Depending on the GOT main unit, communication board, communication module or cable fault, the output from the GOT interface module may remain ON or may remain OFF.  
An external monitoring circuit should be provided to check for output signals which may lead to a serious accident.  
Not doing so can cause an accident due to false output or malfunction.
- If a communication fault (including cable disconnection) occurs during monitoring on the GOT, communication between the GOT and PLC CPU is suspended and the GOT becomes inoperative.  
For bus connection : The CPU becomes faulty and the GOT inoperative.  
For other than bus connection : The GOT becomes inoperative.  
A system where the GOT is used should be configured to perform any significant operation to the system by using the switches of a device other than the GOT on the assumption that a GOT communication fault will occur.  
Not doing so can cause an accident due to false output or malfunction.
- Do not use the GOT as the warning device that may cause a serious accident.  
An independent and redundant hardware or mechanical interlock is required to configure the device that displays and outputs serious warning.  
Failure to observe this instruction may result in an accident due to incorrect output or malfunction.

## [Design Precautions]

### DANGER

- Incorrect operation of the touch switch(s) may lead to a serious accident if the GOT backlight is gone out.

When the GOT backlight goes out, the display section turns black and causes the monitor screen to appear blank, while the input of the touch switch(s) still remains active.

This may confuse an operator in thinking that the GOT is in “screensaver” mode, who then tries to release the GOT from this mode by touching the display section, which may cause a touch switch to operate.

Note that the following occurs on the GOT when the backlight goes out.

- The monitor screen disappears even when the screensaver is not set.
- The monitor screen will not come back on by touching the display section, even if the screensaver is set.

### CAUTION

- Do not bundle the control and communication cables with main-circuit, power or other wiring. Run the above cables separately from such wiring and keep them a minimum of 100mm apart. Not doing so noise can cause a malfunction.

## [Mounting Precautions]

### DANGER

- Before installing or removing the GOT main unit to or from an enclosure, always turn the GOT power OFF before installing or removing the GOT main unit to or from an enclosure. Not doing so can cause a module failure or malfunction.
- Before loading or unloading the communication board, communication module, external I/O interface module or memory card interface module to or from the GOT, always turn the GOT power OFF before loading or unloading the communication board, communication module, external I/O interface module or memory card interface module to or from the GOT. Not doing so can cause a module failure or malfunction.

### CAUTION

- The GOT should be used in the environment given in the general specifications of this user's manual. Not doing so can cause an electric shock, fire, malfunction or product damage or deterioration.
- When mounting the GOT main unit to an enclosure, tighten the mounting screws in the specified torque range. Undertightening can cause a drop, short circuit or malfunction. Overtightening can cause a drop, short circuit or malfunction due to the damage of the screws or module.

## [Mounting Precautions]

### CAUTION

- When loading the communication board, External I/O interface module or communication module to the GOT main unit, fit it to the connection interface of the GOT and tighten the mounting screws in the specified torque range.  
Undertightening can cause a drop, failure or malfunction.  
Overtightening can cause a drop, failure or malfunction due to the damage of the screws or module.
- When loading the communication board to the GOT main unit, take care not to become injured by the components that are installed or surrounding materials.
- When loading the communication board to the GOT main unit, remove any static electricity accumulated on your body before engaging in work.  
Otherwise, this may result in damage to the board.

## [Wiring Precautions]

### DANGER

- Before starting wiring, always turn the GOT power OFF before starting wiring.  
Not doing so may cause an electric shock, product damage or malfunction.

### CAUTION

- Please make sure to ground FG terminal of the GOT power supply unit by applying Class D Grounding (Class 3 Grounding Method) or higher which is used exclusively for the GOT.  
Not doing so may cause an electric shock or malfunction.
- Correctly wire the power supply module on the GOT after confirming the rated voltage and terminal arrangement of the product.  
Not doing so can cause a fire or failure.
- Tighten the terminal screws of the GOT power supply section in the specified torque range.  
Undertightening can cause a short circuit or malfunction.  
Overtightening can cause a short circuit or malfunction due to the damage of the screws or module.
- Exercise care to avoid foreign matter such as chips and wire offcuts entering the module.  
Not doing so can cause a fire, failure or malfunction.
- Plug the bus connection cable by inserting it into the connector of the connected module until it "clicks".  
After plugging, check that it has been inserted snugly.  
Not doing so can cause a malfunction due to a contact fault.
- Plug the communication cable into the connector of the connected module and tighten the mounting and terminal screws in the specified torque range.  
Undertightening can cause a short circuit or malfunction.  
Overtightening can cause a short circuit or malfunction due to the damage of the screws or module.

## [Test Operation Precautions]

### DANGER

- Before performing test operation (bit device on/off, word device's present value changing, timer/counter's set value and present value changing, buffer memory's present value changing) for a user-created monitor screen or system monitoring, read the manual carefully to fully understand how to operate the equipment.  
During test operation, never change the data of the devices which are used to perform significant operation for the system.  
False output or malfunction can cause an accident.

## [Startup/Maintenance Precautions]

### DANGER

- When power is on, do not touch the terminals.  
Doing so can cause an electric shock or malfunction.
- Before starting cleaning or terminal screw retightening, always turn the power OFF before starting cleaning or terminal screw retightening.  
Not switching the power off in all phases can cause a module failure or malfunction.  
Undertightening can cause a short circuit or malfunction.  
Overtightening can cause a short circuit or malfunction due to the damage of the screws or module.

### CAUTION

- Do not disassemble or modify the module.  
Doing so can cause a failure, malfunction, injury or fire.
- Do not touch the conductive and electronic parts of the module directly.  
Doing so can cause a module malfunction or failure.
- The cables connected to the module must be run in ducts or clamped.  
Not doing so can cause the module or cable to be damaged due to the dangling, motion or accidental pulling of the cables or can cause a malfunction due to a cable connection fault.
- When unplugging the cable connected to the module, do not hold and pull the cable portion.  
Doing so can cause the module or cable to be damaged or can cause a malfunction due to a cable connection fault.

## [Backlight Changing Precautions]

### DANGER

- Before changing the backlight, always turn the GOT power OFF (when using a GOT bus connection, also turn OFF the PLC CPU power), and remove the GOT main unit from the panel before changing the backlight.  
Not switching the power off in all phases may cause an electric shock.  
Not removing the unit from the enclosure can cause injury due to a drop.

### CAUTION

- When replacing the backlight, use the gloves.  
Otherwise, it may cause you to be injured.  
If you should directly touch the plated area of the main unit case with hand, be sure to wipe off the fingerprint and so on, and install the main unit case.  
Otherwise, it may cause a trouble or malfunction.
- Start changing the backlight more than 5 minutes after switching the GOT power off.  
Not doing so can cause a burn due to the heat of the backlight.

## [Disposal Precautions]

### CAUTION

- When disposing of the product, handle it as industrial waste.

REVISIONS

\* The manual number is given on the bottom left of the back cover.

| Print Date | * Manual Number  | Revision  |
|------------|------------------|---|
| Jul, 1999  | SH (NA)-080018-A | First edition   |
| Mar, 2000  | SH (NA)-080018-B | <p><u>Partial corrections</u><br/>Section 1.1, Chapter 5, Section 6.2, Section 6.3, Section 6.5, Section 6.6, Section 6.7, Section 6.8</p> <p><u>Partial additions</u><br/>Section 2.1, Section 2.3, Section 3.1, Section 3.2, Section 3.3, Chapter 4, Section 6.1, Section 6.4, Section 7.4, Appendix 1, Appendix 2, Appendix 3, Index</p> <p><u>Additions</u><br/>Section 2.2, Section 2.4, Section 6.9, Section 8.4</p> <p><u>Additional mode</u><br/>Descriptions of A951GOT-QTBD/QSBD/QLBD(-M3) are added.<br/>Descriptions of A950/951/953/956GOT-TBD(-M3) are added.</p> |
| Feb, 2001  | SH (NA)-080018-C | <p><u>Partial additions</u><br/>Section 1.1, Section 2.1, Section 2.2, Section 2.3, Section 2.4, Section 3.1, Section 3.3, Section 4.1, Section 6.1, Section 6.2, Section 6.4, Section 6.7, Section 6.8, Section 6.9, Section 6.10, Section 6.11, Section 6.12, Section 7.4, Section 8.2, Section 8.3, Appendix 1, Appendix 2</p> <p><u>Additions</u><br/>Section 6.3, Section 6.5, Section 6.6</p> <p><u>Additional mode</u><br/>Descriptions of A956WGOT-TBD is added.</p>  |
| May, 2001  | SH (NA)-080018-D | <p><u>Partial corrections</u><br/>Section 6.3.1</p> <p><u>Partial additions</u><br/>Section 1.1, Section 2.2, Section 2.3, Section 3.2, Section 6.7.1, Section 6.12.2, Section 9.2, Appendix 2</p> <p><u>Additions</u><br/>Chapter 8</p>  |
| Feb, 2002  | SH (NA)-080018-E | <p><u>Partial corrections</u><br/>SAFETY PRECAUTIONS</p>  |
|            |                  |   |

Japanese Manual Version SH-080011-F

This manual confers no industrial property rights or any rights of any other kind, nor does it confer any patent licenses. Mitsubishi Electric Corporation cannot be held responsible for any problems involving industrial property rights which may occur as a result of using the contents noted in this manual.

## INTRODUCTION

Thank you for choosing the Mitsubishi Graphic Operation Terminal.  
Before using the equipment, please read this manual carefully to use the equipment to its optimum.  
A copy of this manual should be forwarded to the end user.

## CONTENTS

|  |                     |
|--|---------------------|
| SAFETY PRECAUTIONS.....                        | A- 1                |
| 1. ABOUT THE MANUALS.....                      | A-10                |
| 2. ABBREVIATION AND GENERIC NAMES .....        | A-11                |
| 3. PACKING LIST .....                          | A-13                |
| <b>1 OVERVIEW</b>                              | <b>1- 1 to 1- 3</b> |
| 1.1 Features .....                             | 1- 2                |
| <b>2 SYSTEM CONFIGURATION</b>                  | <b>2- 1 to 2- 8</b> |
| 2.1 Overall Configuration .....                | 2- 1                |
| 2.2 System Configuration of the GOT .....      | 2- 3                |
| 2.3 Component List .....                       | 2- 3                |
| 2.4 Software Packages to be Used .....         | 2- 7                |
| 2.5 Unusable Conventional Products .....       | 2- 7                |
| 2.6 Notes on Q4ARCPU Duplex System .....       | 2- 8                |
| <b>3 PERFORMANCE</b>                           | <b>3- 1 to 3- 5</b> |
| 3.1 General Specifications .....               | 3- 1                |
| 3.2 Performance Specifications .....           | 3- 2                |
| 3.3 Power Supply Specifications .....          | 3- 5                |
| <b>4 NAMES OF THE PARTS AND THEIR SETTINGS</b> | <b>4- 1 to 4- 2</b> |
| <b>5 ROUGH PRE-OPERATION PROCEDURE</b>         | <b>5- 1 to 5- 2</b> |
| <b>6 HANDLING</b>                              | <b>6- 1 to 6-22</b> |
| 6.1 GOT Main Unit .....                        | 6- 1                |
| 6.1.1 Handling instructions .....              | 6- 1                |
| 6.1.2 Installation method .....                | 6- 3                |
| 6.1.3 Wiring method .....                      | 6- 4                |
| 6.1.4 Installation of handy type GOT .....     | 6- 5                |
| 6.2 Protective Sheet.....                      | 6- 7                |
| 6.2.1 Protective sheet types.....              | 6- 7                |
| 6.2.2 Mounting procedure .....                 | 6- 7                |



|  |      |
|--|------|
| 6.3 Memory board (A956WGOT Only).....                  | 6- 8 |
| 6.3.1 Memory board types .....                         | 6- 8 |
| 6.3.2 Mounting procedure .....                         | 6- 8 |
| 6.4 Memory Card Interface Module .....                 | 6- 9 |
| 6.4.1 Memory card interface module type .....          | 6- 9 |
| 6.4.2 Mounting procedure .....                         | 6- 9 |
| 6.4.3 PC card types .....                              | 6-10 |
| 6.4.4 Battery changing timing and method .....         | 6-10 |
| 6.4.5 Loading and unloading procedures .....           | 6-11 |
| 6.5 Compact flash card (A956WGOT Only).....            | 6-12 |
| 6.5.1 Memory board types .....                         | 6-12 |
| 6.5.2 Mounting procedure .....                         | 6-12 |
| 6.6 Communication Board (A956WGOT Only).....           | 6-14 |
| 6.6.1 Communication board types .....                  | 6-14 |
| 6.6.2 Mounting procedure .....                         | 6-14 |
| 6.7 Communication Module (A956GOT, A956WGOT Only)..... | 6-15 |
| 6.7.1 Connection module types .....                    | 6-15 |
| 6.7.2 Mounting procedure .....                         | 6-16 |
| 6.8 Printer Interface Module.....                      | 6-17 |
| 6.8.1 Printer interface module type .....              | 6-17 |
| 6.8.2 How to connect the printer interface module..... | 6-17 |
| 6.8.3 Printer types .....                              | 6-18 |
| 6.8.4 Connecting procedure.....                        | 6-18 |
| 6.9 External I/O Module .....                          | 6-19 |
| 6.9.1 External I/O module type.....                    | 6-19 |
| 6.9.2 Mounting procedure .....                         | 6-19 |
| 6.10 Bar Code Reader .....                             | 6-20 |
| 6.10.1 Bar cord reader types.....                      | 6-20 |
| 6.10.2 Connecting procedure.....                       | 6-20 |
| 6.11 Debug Stand .....                                 | 6-21 |
| 6.11.1 Debug stand types .....                         | 6-21 |
| 6.11.2 Mounting procedure .....                        | 6-21 |
| 6.12 Attachment (A95*GOT only) .....                   | 6-22 |
| 6.12.1 Attachment type .....                           | 6-22 |
| 6.12.2 Mounting procedure .....                        | 6-22 |

|                                     |                     |
|-------------------------------------|---------------------|
| <b>7 MAINTENANCE AND INSPECTION</b> | <b>7- 1 to 7- 4</b> |
|-------------------------------------|---------------------|

|   |      |
|---|------|
| 7.1 Instructions for Maintenance and Inspection .....   | 7- 1 |
| 7.2 Daily Inspection .....                              | 7- 2 |
| 7.3 Periodic Inspection.....                            | 7- 2 |
| 7.4 How to Change the Backlight for Liquid Crystal..... | 7- 3 |

|                        |                     |
|------------------------|---------------------|
| <b>8 EMC Directive</b> | <b>8- 1 to 8-15</b> |
|------------------------|---------------------|

|   |      |
|---|------|
| 8.1 Requirements for conformance to EMC Directive ..... | 8- 1 |
| 8.1.1 Standards applicable to the EMC Directive.....    | 8- 2 |
| 8.1.2 Control cabinet .....                             | 8- 3 |
| 8.1.3 Grounding.....                                    | 8- 4 |

|   |      |
|---|------|
| 8.2 System Configuration when EMC Directive is Applicable .....       | 8- 5 |
| 8.2.1 Overall Configuration .....                                     | 8- 5 |
| 8.2.2 Connection Format.....  | 8- 5 |
| 8.2.3 About Models Applicable to the EMC Directive .....              | 8- 6 |
| 8.2.4 About the Cable Used .....                                      | 8- 7 |
| 8.3 Wiring precautions the part which matches the EMC Directives..... | 8- 8 |
| 8.3.1 Method to connect the power wire and ground wire .....          | 8- 8 |
| 8.3.2 Grounding the ground cable .....                                | 8- 9 |
| 8.3.3 Grounding the cable.....  | 8-15 |

|   |                     |
|---|---------------------|
| <b>9 ERROR CODES AND ERROR MESSAGES</b> | <b>9- 1 to 9-17</b> |
|---|---------------------|

|   |      |
|---|------|
| 9.1 Definition of the Error Codes and Messages Displayed..... | 9- 1 |
| 9.2 Error Code and Error Message List.....                    | 9- 2 |
| 9.3 Precautions for Installation of ROM_BIOS.....             | 9- 6 |
| 9.4 Troubleshooting in bus connection.....                    | 9- 9 |
| 9.4.1 Locating error positions.....                           | 9- 9 |
| 9.4.2 Further locating error positions .....                  | 9-14 |
| 9.4.3 Specific example of troubleshooting.....                | 9-15 |
| 9.5 Troubleshooting for monitoring.....                       | 9-16 |

|                   |                         |
|-------------------|-------------------------|
| <b>APPENDICES</b> | <b>APP- 1 to APP- 7</b> |
|-------------------|-------------------------|

|  |        |
|--|--------|
| Appendix1 Outline Dimension Drawings .....   | APP- 1 |
| Appendix2 Depth at the Time of Communication Module Loading (A956GOT/A956WGOT Only)..... | APP- 3 |
| Appendix3 Outline Dimension Drawings of Bus Connection Cables .....                      | APP- 7 |

|              |                 |
|--------------|-----------------|
| <b>INDEX</b> | <b>INDEX- 1</b> |
|--------------|-----------------|

## 1. ABOUT THE MANUALS

The following manuals are related to this product.  
Refer to the following list and request the required manuals.

### Related Manuals

| Manual name   | Manual number<br>(Model code)  |
|---|--------------------------------|
| <p>GT Works Version5/GT Designer Version5 Operating Manual (Start up Manual)</p> <p>Describes how to install GT Works Version 5/GT Designer Version 5 into a personal computer and how to browse the online manuals.</p> <p>(Found in the packing of the GT Works Version5/GT Designer Version5)</p>  | <p>IB-0800143<br/>(13JU06)</p> |
| <p>GOT900 Series Operating Manual (Introductory Manual)</p> <p>For those who use the GOT for the first time, describes the way to create a monitor screen on GT Designer, transfer monitor data to the GOT, and display it on the screen. (Available as option)</p>   | <p>SH-080116<br/>(13JU07)</p>  |
| <p>GT Works Version5/GT Designer Version5 Reference Manual</p> <p>Deals with the system configuration of GT Works Version5/GT Designer Version5, the screen makeup of the GT Designer, the general description of various monitoring functions, the procedure for displaying the monitor screen on the GOT, and how to use the help function. (Available as option)</p>   | <p>SH-080117<br/>(13JF95)</p>  |
| <p>GOT-A900 Series User's Manual (GT Works Version5/GT Designer Version5 compatible Connection System Manual)</p> <p>Gives the specifications, system configuration, setting method and connection diagram of each connection form available for the GOT-A900 series. (Available as option)</p>   | <p>SH-080119<br/>(13JR20)</p>  |
| <p>GOT-A900 Series Operating Manual (GT Works Version5/GT Designer Version5 compatible Extended • Option Functions Manual)</p> <p>Provides the specifications of the utility, system monitoring, ladder monitoring, special function unit monitoring, network monitoring functions and list editor functions available for the GOT-A900 series and how to operate the dedicated monitor screen. (Available as option)</p> | <p>SH-080118<br/>(13JU08)</p>  |
| <p>GT Simulator Version5 Operating Manual</p> <p>Explains the system configuration, screen makeup and using methods of GT Simulator. (Available as option)</p>  | <p>SH-080120<br/>(13JU09)</p>  |
| <p>GT SoftGOT Version5 Operating Manual</p> <p>Explains the system configuration, screen makeup and using methods of GT SoftGOT. (Available as option)</p>  | <p>SH-080156<br/>(13JU12)</p>  |

## 2. ABBREVIATIONS AND GENERIC TERMS IN THIS MANUAL



Abbreviations and generic terms used in this manual are described as follows:

| Abbreviations and generic terms |   | Description   |
|---------------------------------|---|---|
| GOT                             | A950GOT   | Generic term of A950GOT-TBD, A950GOT-SBD, A950GOT-LBD, A950GOT-TBD-M3, A950GOT-SBD-M3 and A950GOT-LBD-M3  |
|                                 | A951GOT   | Generic term of A951GOT-TBD, A951GOT-SBD, A951GOT-LBD, A951GOT-TBD-M3, A951GOT-SBD-M3 and A951GOT-LBD-M3  |
|                                 | A951GOT-Q   | Generic term of A951GOT-QTBD, A951GOT-QSBD, A951GOT-QLBD, A951GOT-QTBD-M3, A951GOT-QSBD-M3 and A951GOT-QLBD-M3                                  |
|                                 | A953GOT   | Generic term of A953GOT-TBD, A953GOT-SBD, A953GOT-LBD, A953GOT-TBD-M3, A953GOT-SBD-M3 and A953GOT-LBD-M3  |
|                                 | A956GOT   | Generic term of A956GOT-TBD, A956GOT-SBD, A956GOT-LBD, A956GOT-TBD-M3, A956GOT-SBD-M3 and A956GOT-LBD-M3  |
|                                 | A95 *GOT  | Generic term of A956GOT, A953GOT, A951GOT, A951GOT-Q and A950GOT  |
|                                 | A956WGOT  | Abbreviation of A956WGOT-TBD  |
| A85 *GOT                        |   | Generic term of A850GOT, A851GOT, A852GOT and A853GOT   |
| Communication board             | Bus connection board  | Generic term of A9GT-50WQBUISS and A9GT-50WBUISS  |
|                                 | Serial communication board  | Generic term of A9GT-50WRS4 and A9GT-50WRS2   |
| Communication unit              | Bus connection unit   | Generic term of A9GT-QBUS2SU, A9GT-BUISSU, A9GT-BUS2SU, A7GT-BUISS and A7GT-BUS2S   |
|                                 | Data link unit  | Generic term of A7GT-J71AP23, A7GT-J71AR23 and A7GT-J71AT23B  |
|                                 | Network unit  | Generic term of A7GT-J71LP23 and A7GT-J71BR13   |
|                                 | CC-Link communication unit  | Generic term of A8GT-J61BT13 and A8GT-J61BT15   |
|                                 | Ethernet communication unit   | Abbreviation of A9GT-J71E71-T   |
| Option unit                     | External I/O unit   | Abbreviation of A8GT-50KBF type external I/O interface unit   |
|                                 | Printer interface unit  | Abbreviation of A9GT-50PRF type Printer interface unit  |
|                                 | Memory card interface unit  | Abbreviation of A1SD59J-MIF type Memory card interface unit   |
| Option                          | Protection sheet  | Abbreviation of A9GT-50PSC and A9GT-50WPSC type transparent protection sheets   |
|                                 | Backlight   | Abbreviation of A9GT-50LT type backlight  |
|                                 | Debug stand   | Abbreviation of A9GT-50STAND and A9GT-50WSTAND type debug stand   |
|                                 | PC card ( memory card )   | Abbreviation of PC card with PCMCIA Ver.2.1   |
|                                 | Compact flash card  | Abbreviation of compact flash card with Compact Flash TM. (Compact flash TM is a trademark of SunDisk.)   |
|                                 | Memory board  | Abbreviation of A9GT-FNB, A9GT-FNB1M, A9GT-FNB2M, A9GT-FNB4M, A9GT-FNB8M, A9GT-QFNB, A9GT-QFNB4M, A9GT-QFNB8M type option function memory board |
|                                 | Attachment  | Abbreviation of A85GT-95ATT attachment  |
|                                 | Ten-key Panel   | Abbreviation of A8GT-TK ten-key Panel   |
|                                 | A7GT-CNB  | Abbreviation of A7GT-CNB bus connector conversion box   |
|                                 | A9GT-QCNB   | Abbreviation of A9GT-QCNB bus connector conversion box  |
| Software                        | GT Works Version 5  | Abbreviation of SW5D5C-GTWORKS-E software package   |
|                                 | GT Designer Version 5   | Generic term of SW5D5C-GOTR-PACKE software package and SW5D5C-GOTR-PACKEV software package  |
|                                 | GT Designer   | Abbreviation of image creation software GT Designer for GOT900  |
|                                 | GT Simulator  | Abbreviation of GT Simulator screen simulator GOT900  |
|                                 | GT Converter  | Abbreviation of data conversion software GT Converter for GOT900  |
|                                 | GT Debugger   | Abbreviation of debugging software GT Debugger  |
|                                 | GT Manager  | Abbreviation of GT Manager data editing software for GOT900   |
|                                 | GT SoftGOT  | Abbreviation of GT SoftGOT monitoring software  |
|                                 | GX Developer  | Generic term of SW□D5C-GPPW-E/SW□D5F-GPPW-E software packages   |
| GX Simulator                    | Generic term of SW□D5C-LLT-E ladder logic test tool function software package (SW5D5C-LLT-E or later) |   |

| Abbreviations and generic terms         |  | Description   |
|---|--|---|
| CPU                                     | QCPU (Q Mode)                                  | Generic term of Q00JCPU, Q00CPU, Q01CPU, Q02CPU, Q02HCPU, Q06HCPU, Q12HCPU and Q25HCPU CPU units  |
|   | QCPU (A Mode)                                  | Generic term of Q02CPU-A, Q02HCPU-A and Q06HCPU-A CPU units   |
|   | QCPU   | Generic term of QCPU (Q Mode) and QCPU (A Mode)   |
|   | QnACPU (Large Type)                            | Generic term of Q2ACPU, Q2ACPU-S1, Q3ACPU, Q4ACPU and Q4ARCPU CPU units   |
|   | QnACPU (Small Type)                            | Generic term of Q2ASCPU, Q2ASCPU-S1, Q2ASHCPU and Q2ASHCPU-S1 CPU units   |
|   | QnACPU   | Generic term of QnACPU (Large Type) and QnACPU (Small Type)   |
|   | AnUCPU   | Generic term of A2UCPU, A2UCPU-S1, A3UCPU and A4UCPU CPU units  |
|   | AnACPU   | Generic term of A2ACPU, A2ACPU-S1 and A3ACPU CPU units  |
|   | AnNCPUCPU                                      | Generic term of A1NCPUCPU, A2NCPUCPU, A2NCPUCPU-S1 and A3NCPUCPU CPU units  |
|   | ACPU (Large Type)                              | Generic term of AnUCPU, AnACPU and AnNCPUCPU CPU units  |
|   | A2US(H)CPU                                     | Generic term of A2USCPU, A2USCPU-S1 and A2USHCPU-S1 CPU units   |
|   | AnS(H)CPU                                      | Generic term of A1SCPU, A1SHCPU, A2SCPU and A2SHCPU CPU units   |
|   | A1SJ(H)CPU                                     | Generic term of A1SJCPU-S3 and A1SJHCPU CPU units   |
|   | ACPU (Small Type)                              | Generic term of A2US(H)CPU, AnS(H)CPU and A1SJ(H)CPU CPU units  |
|   | ACPU   | Generic term of ACPUCPU (Large Type), ACPUCPU (Small Type) and A1FXCPU CPU units  |
|   | FXCPU  | Generic term of FX0 series, FX0N series, FX0S series, FX1 series, FX1N series, FX1S series, FX2 series, FX2C series, FX2N series, FX2NC series CPU unit   |
|   | Motion controller CPU                          | Generic term of A373UCPU, A373UCPU-S3, A273UCPU, A273UHCPU, A273UHCPU-S3, A171SCPU-S3, A171SHCPU, A172SHCPU CPU unit  |
| FA controller                           | Generic term of LM610, LM7600, LM8000 CPU unit |   |
| GPP function peripheral connection unit | G4   | Abbreviation of AJ65BT-G4-S3  |
| Ethernet unit                           | E71  | Generic term of AJ71E71-S3, A1SJ71E71-B2-S3 and A1SJ71E71-B5-S3   |
|   | QE71   | Generic term of AJ71QE71, A1SJ71QE71-B2, AJ71QE71-B5 and A1SJ71QE71-B5  |
|   | Q series-compatible E71                        | Generic term of QJ71E71, QJ71E71-B2 and QJ71E71-100   |
| Other PLC                               | Omron PLC                                      | Generic term of C200HS, C200H, C200H $\alpha$ series(C200HX, C200HG, C200HE), CQM1, C1000H,C2000H,CV500, CV1000, CV2000, CVM1-CPU11, CVM1-CPU21, CS1 CPU unit   |
|   | Yasukawa PLC                                   | Generic term of GL60S, GL60H, GL70H, GL120, GL130, CP-9200SH, CP-9300MS, MP-920, MP-930, MP-940, CP-9200(H) and PROGIC-8 CPU unit   |
|   | SLC500 Series                                  | Generic term of SLC500-20, SLC500-30, SLC500-40, SLC5/01 SLC5/02, SLC5/03, SLC5/04 SLC5/05  |
|   | MicroLogix1000 Series                          | Generic term of 1761-L10BWA, 1761-L10BWB, 1761-L16AWA, 1761-L16BWA, 1761-L16BWB, 1761-L16BBB, 1761-L32AWA, 1761-L32BWA, 1761-L32BWB, 1761-L32BBB, 1761-L32AAA, 1761-L20AWA-5A, 1761-L20BWA-5A, 1761-L20BWB-5A |
|   | MicroLogix1500 Series                          | Abbreviation of 1764-LSP  |
|   | Allen-Bradley PLC                              | Generic term of SLC 500 Series, MicroLogix1000 Series, MicroLogix1500 Series  |
|   | Sharp PLC                                      | Generic term of JW-21CU, JW-22CU, JW-31CUH, JW-32CUH, JW-33CUH, JW-50CUH, JW-70CUH, JW-100CUH CPU unit  |
|   | PROSEC T Series                                | Generic term of T3, T3H CPU unit  |
|   | PROSEC V Series                                | Abbreviation of Model3000 CPU unit  |
|   | Toshiba PLC                                    | Generic term of PROSEC T Series and PROSEC V Series   |
|   | SIEMENS PLC                                    | Generic term of SIMATIC S7-300 Series and SIMATIC S7-400 Series CPU unit  |
|   | Large type H series                            | Generic term of H-302(CPU2-03H), H-702(CPU2-07H), H-1002(CPU2-10H), H-2002(CPU2-20H), H-4010(CPU3-40H), H-300(CPU-03Ha), H-700(CPU-07Ha), H-2000(CPU-20Ha)  |
|   | H200 to 252 Series                             | Generic term of H-200(CPU-02H, CPE-02H), H-250(CPU21-02H), H-252(CPU22-02H), H-252B(CPU22-02HB), H-252C(CPU22-02HC, CPE22-02HC)   |
|   | H Series board type                            | Generic term of H-20DR, H-28DR, H-40DR, H-64DR, H-20DT, H-28DT, H-40DT, H-64DT, HL-40DR, HL-64DR  |
|   | EH-150 Series                                  | Generic term of EH-CPU104, EH-CPU208, EH-CPU308, EH-CPU316  |
|   | HITACHI PLC (HIDIC H Series)                   | Generic term of large type H series,H-200 to 252 Series H Series board type, EH-150 Series  |
|   | Matsushita Electric Works PLC                  | Generic term of FP0-C16CT, FP0-C32CT, FP1-C24C, FP1-C40C, FP2, FP3, FP5, FP10(S), FP10SH, FP-M(C20TC) and FP-M(C32TC)   |
| Others                                  | Memory   | abbreviation of memory (flash memory) in the GOT  |
|   | OS   | Abbreviation of GOT system software   |
|   | Object   | Setting data for dynamic image  |
|   | Personal Computer                              | Personal computer where the corresponding software package is installed   |

### 3. PACKING LIST

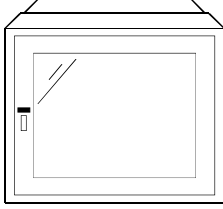
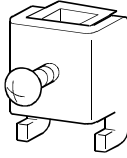
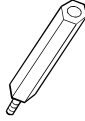
After unpacking, confirm that you have received the following products.

| Product   | Quantity |
|---|----------|
| GOT main unit   | 1        |
| Mounting fixture   | 4        |
| Communication module securing fixture (A956GOT, A956WGOT only)   | 3        |
| Seal (A956WGOT only)<br>* For use when closing the bus connection board setting switch confirmation hole.                | 1        |
| A950GOT-TBD/SBD/LBD(-M3), A951GOT-QTBD/QSBD/QLBD(-M3),<br>A951GOT-TBD/SBD/LBD(-M3), A953GOT-TBD/SBD/LBD(-M3),<br>A956GOT-TBD/SBD/LBD(-M3) User's Manual (Hardware)*<br>A956WGOT-TBD User's Manual (Hardware)* | 1        |

\* Changes with the GOT you purchased.

## 1 OVERVIEW

1

This user's manual explains the specifications, handling and other information of the A950GOT/A951GOT/A953GOT/A956GOT/A956WGOT graphic operation terminal module (abbreviated to the GOT).

The GOT can be used as an electronic operator panel which has achieved on its monitor screen the switch operation, lamp indication, data display, message display and other operations which were previously performed on an operator panel.

The following GOT types are available.

| Type            | Rough Specifications                       |  |  |   |                      |
|-----------------|--|--|--|---|----------------------|
|                 | Screen size<br>[cm (inch)]                 | Interface built into main<br>unit  | Display section  | Display color<br>[color]                    | Power<br>Supply type |
| A950GOT-TBD     | 15 (6)                                     | Built-in RS-422<br>communication<br>interface                                      | TBD(-M3): TFT color<br>liquid crystal<br>SBD(-M3): STN color<br>liquid crystal<br>LBD(-M3): Monochrome<br>liquid crystal | TBD(-M3): 256<br>SBD(-M3): 8<br>LBD(-M3): 2 | 24VDC                |
| A950GOT-SBD     |  |  |  |   |                      |
| A950GOT-LBD     |  |  |  |   |                      |
| A950GOT-TBD-M3  |  |  |  |   |                      |
| A950GOT-SBD-M3  |  |  |  |   |                      |
| A950GOT-LBD-M3  |  |  |  |   |                      |
| A951GOT-QTBD    |  | Built-in bus<br>communication<br>interface<br>(For QCPU (Q Mode))                  |  |   |                      |
| A951GOT-QSBD    |  |  |  |   |                      |
| A951GOT-QLBD    |  |  |  |   |                      |
| A951GOT-QTBD-M3 |  |  |  |   |                      |
| A951GOT-QSBD-M3 |  |  |  |   |                      |
| A951GOT-QLBD-M3 |  |  |  |   |                      |
| A951GOT-TBD     |  | Built-in bus<br>communication<br>interface<br>(For A/QnA/Motion<br>controller CPU) |  |   |                      |
| A951GOT-SBD     |  |  |  |   |                      |
| A951GOT-LBD     |  |  |  |   |                      |
| A951GOT-TBD-M3  |  |  |  |   |                      |
| A951GOT-SBD-M3  |  |  |  |   |                      |
| A951GOT-LBD-M3  |  |  |  |   |                      |
| A953GOT-TBD     |  | Built-in RS-232C<br>communication<br>interface                                     |  |   |                      |
| A953GOT-SBD     |  |  |  |   |                      |
| A953GOT-LBD     |  |  |  |   |                      |
| A953GOT-TBD-M3  |  |  |  |   |                      |
| A953GOT-SBD-M3  |  |  |  |   |                      |
| A953GOT-LBD-M3  |  |  |  |   |                      |
| A956GOT-TBD     | Built-in communication<br>module interface |  |  |   |                      |
| A956GOT-SBD     |  |  |  |   |                      |
| A956GOT-LBD     |  |  |  |   |                      |
| A956GOT-TBD-M3  |  |  |  |   |                      |
| A956GOT-SBD-M3  |  |  |  |   |                      |
| A956GOT-LBD-M3  |  |  |  |   |                      |
| A956WGOT-TBD    | 18 (7)                                     | Built-in communication<br>board/module interface                                   |  |   |                      |

1.1 Features

- (1) Medium-size display device occupying minimum installation area  
 The A95\*GOT/A956WGOT was made smaller in outline dimensions to greatly reduce the panel cut dimensions.  
 You can install the GOT according to your application.

For A95 \* GOT

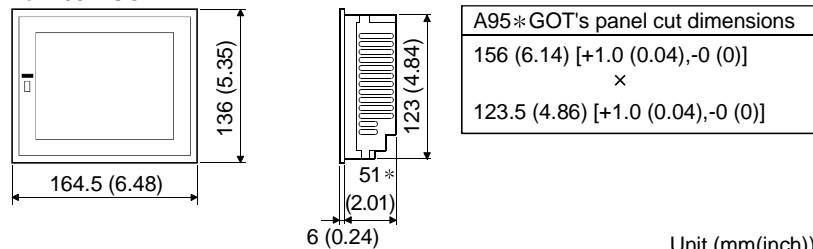

\*59 mm (2.32 in) for A95\*GOT-TBD.

For A956WGOT

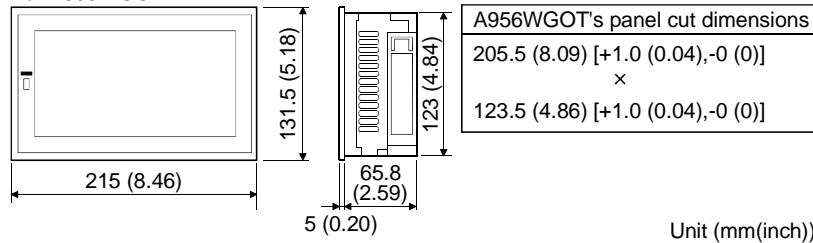

- (2) Fast data transfer of OS and screen data by memory card  
 The PC card for OS and screen data can be created easily on a personal computer. By loading the created card into the memory card interface unit, you can exchange the OS and screen data rapidly. (RS-232C data transfer can also be made as conventionally.)  
 Also, a compact flash card can be used with the A956WGOT.

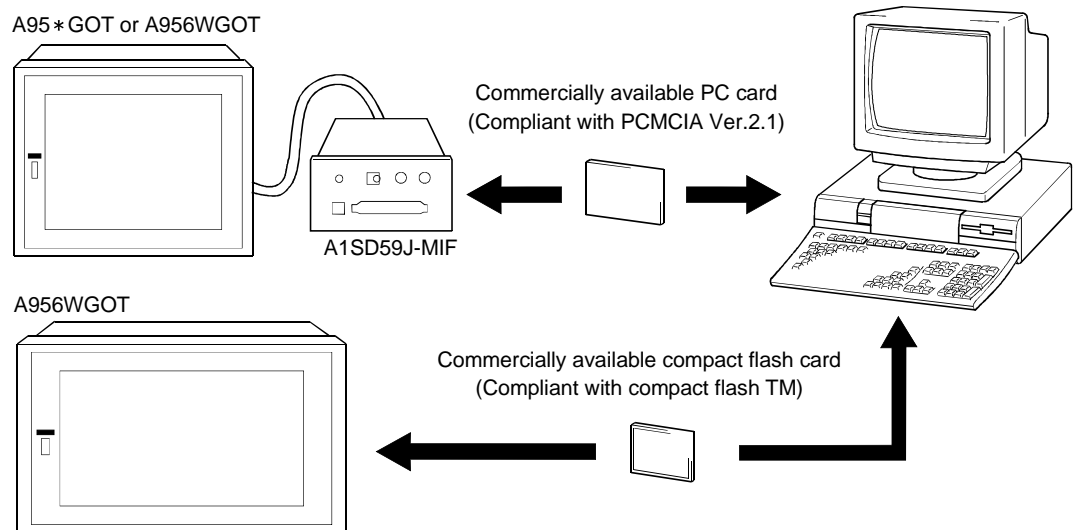

\* ROM\_BIOS cannot be installed with the compact flash card.



**(3) Compatible with a wide variety of connection forms**

The GOT models each contain their communication interfaces so that you can choose the connection form which meets your system.

The A951GOT-Q, A951GOT comes with a bus communication interface to make a bus connection for fast communication, the A953GOT has an RS-232C interface and A950GOT includes an RS-422 communication interface to make a CPU direct connection or computer link connection.

The A956GOT used with a communication module can make a bus connection, MELSECNET connection or CC-Link connection.

The A956WGOT used with a communication module or communication board can make a bus connection, Direct connection to CPU, computer link connection, MELSECNET connection, CC-Link connection or Ethernet connection.

**(4) Heavy-duty body usable in rigorous environment and operation**

The standard display section of the GOT complies with the IP65F, the IP67 and the NEMA4 Waterproof, Dustproof Standard and is usable in a wide range of environment.

**(5) Maintenance function further enhanced in affinity with PLC**

Upgraded alarm history function

The GOT can support the failure occurrence counting function, cumulative failure time totalizing function and history printing function, and start ladder monitoring with the corresponding device searched with a single keystroke at the failure detail display time.

**(6) Improvement of safety by upgraded security function**

- Supporting the operation protective function using up to 16 levels of passwords, the GOT can hide the display or disable input operation according to the password level. You can achieve hidden screens and hidden operations and easily change the display data per GOT used.
- You can specify the time delay function (ON delay/OFF delay) of the touch switches, double-pushing switches and interlock conditions to reduce malfunctions due to wrong key pushing.

**(7) Wide, easy-to-see screen (A956WGOT only)**

The A956WGOT can lay out more objects on the screen than it is possible with the A95\*GOT. By utilizing the monitor screen data of the A95\*GOT, the A956WGOT enables numeric value entry without hiding the monitor screen with a window for numeric value entry. This is achieved by arranging the ten keys for numeric value input next to the monitor screen data.

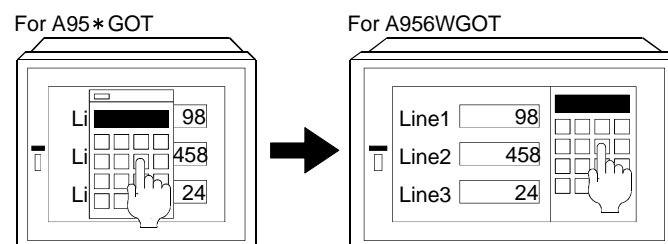

Numeric values can be entered without hiding the monitor screen with a window for numeric value entry.

## 2 SYSTEM CONFIGURATION

This chapter explains the system configuration of the GOT.

### 2.1 Overall Configuration

#### (1) Overall configuration of the A95\*GOT

The overall configuration of the A95\*GOT is shown below.

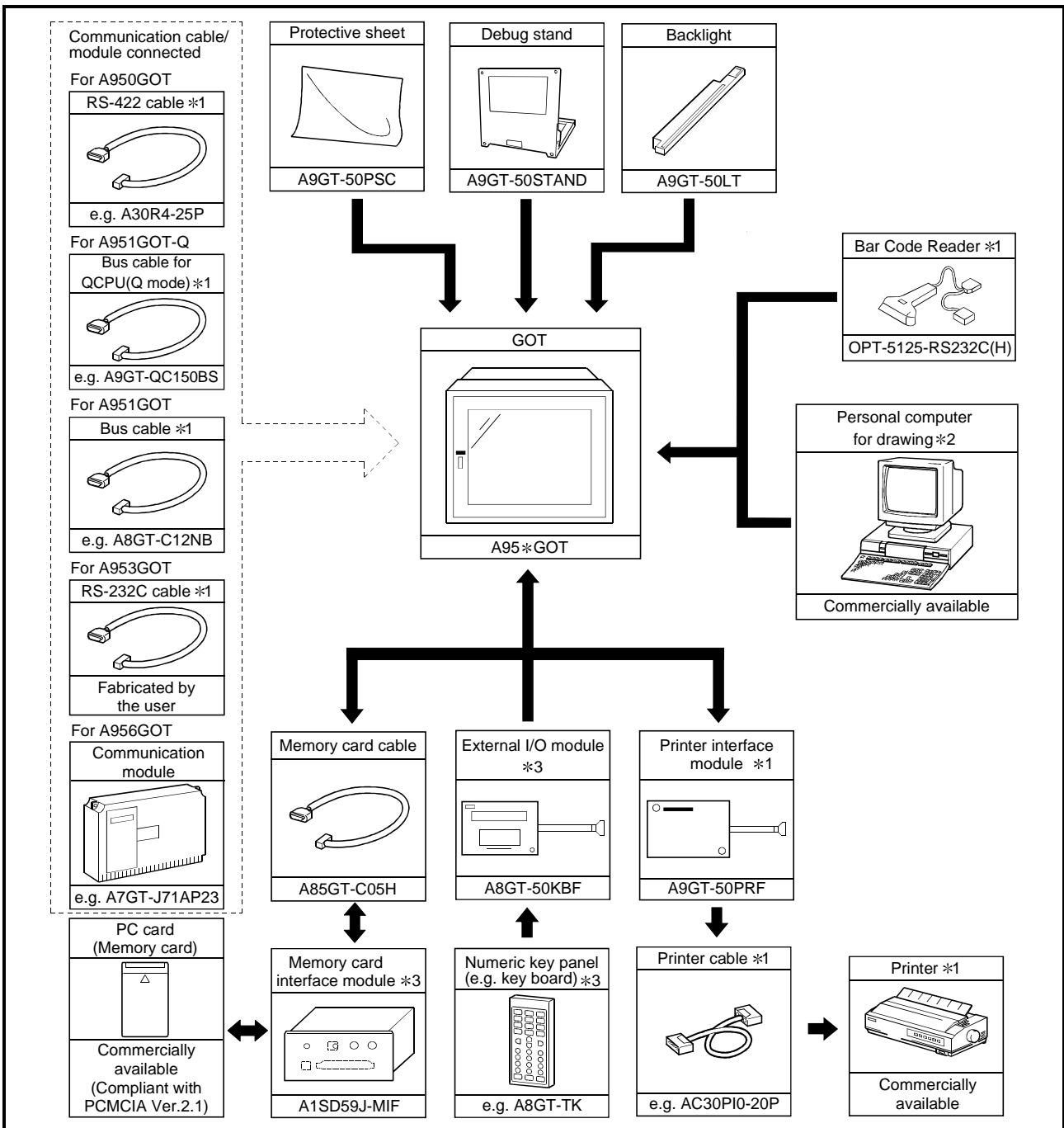

\*1 For details of the system configuration, refer to the [GOT-A900 Series User's Manual (GT Works Version5/GT Designer Version5 compatible Connection System Manual)].

\*2 For details of the system configuration, refer to the [GT Works Version5/GT Designer Version5 Reference Manual].

\*3 For details on the system configuration, refer to the User's Manual of each module.

(2) Overall configuration of the A956WGOT

The overall configuration of the A956WGOT is shown below.

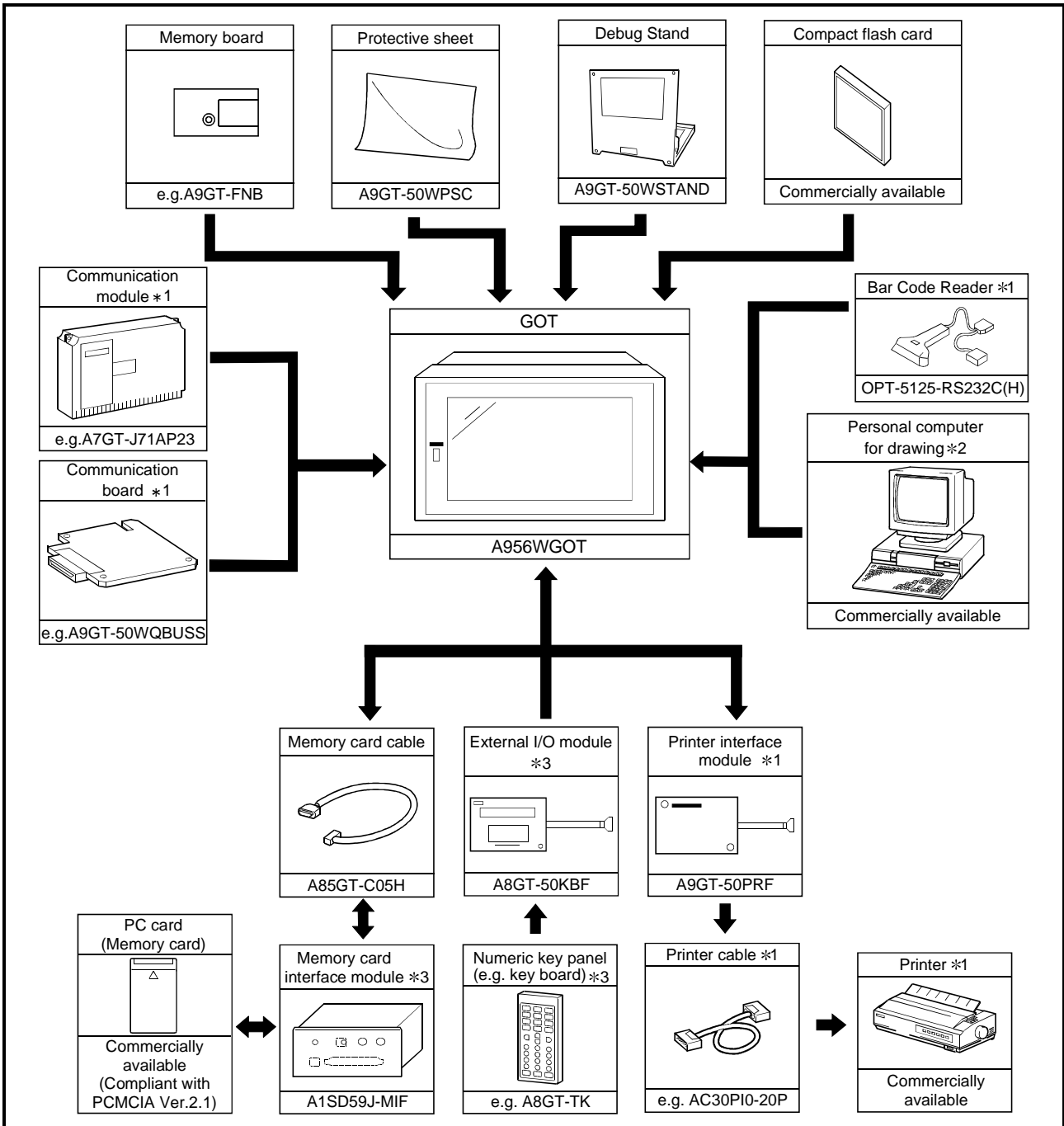

\*1 For details of the system configuration, refer to the [GOT-A900 Series User's Manual (GT Works Version5/GT Designer Version5 compatible Connection System Manual)].

\*2 For details of the system configuration, refer to the [GT Works Version5/GT Designer Version5 Reference Manual].

\*3 For details on the system configuration, refer to the User's Manual of each module.

## 2.2 System Configuration of the GOT

Each GOT incorporates a different type of communication interface and, therefore, the connection mode differs from GOT to GOT used.

The connections modes allowed for each GOT are shown below.

| Type        | Bus connection |                             | CPU direct Connection |                       | MELSECNET connection | Computer link connection |                       | CC-Link connection | Ethernet connection |
|-------------|----------------|-----------------------------|-----------------------|-----------------------|----------------------|--------------------------|-----------------------|--------------------|---------------------|
|             | QCPU (Q mode)  | A/QnA/Motion controller CPU | RS-422 communication  | RS-232C communication |                      | RS-422 communication     | RS-232C communication |                    |                     |
| A950GOT     | ×              | ×                           | ○                     | ×                     | ×                    | ○                        | ×                     | ×                  | ×                   |
| A951GOT-Q   | ○              | ×                           | ×                     | ×                     | ×                    | ×                        | ×                     | ×                  | ×                   |
| A951GOT     | ×              | ○                           | ×                     | ×                     | ×                    | ×                        | ×                     | ×                  | ×                   |
| A953GOT     | ×              | ×                           | ×                     | ○                     | ×                    | ×                        | ○                     | ×                  | ×                   |
| A956GOT *1  | ○              | ○                           | ×                     | ×                     | ○                    | ×                        | ×                     | ○                  | ○                   |
| A956WGOT *2 | ○              | ○                           | ○                     | ○                     | ○                    | ○                        | ○                     | ○                  | ○                   |

○: Connection possible ×: Connection not possible

\*1 The A956GOT can be connected as shown above by the installation of the communication unit.

\*2 The A956WGOT can be connected as shown above by the installation of the communication unit and the communication board.

\*3 For details of each connection mode, refer to the GOT-A900 Series User's Manual (GT Works Version5/GT Designer Version5 compatible Connection System Manual).

## 2.3 Component List

## (1) List of Components Available for the A95\*GOT

| Component   | Type            | Remarks  |
|---|-----------------|--|
| A950GOT<br>(Built-in RS-422 communication interface)                              | A950GOT-TBD     | 256 colors, 1M byte built-in memory                              |
|   | A950GOT-SBD     | 8 colors, 1M byte built-in memory                                |
|   | A950GOT-LBD     | Monochrome, 1M byte built-in memory                              |
|   | A950GOT-TBD-M3  | 256 colors, 3M byte built-in memory, compatible with optional OS |
|   | A950GOT-SBD-M3  | 8 colors, 3M byte built-in memory, compatible with optional OS   |
|   | A950GOT-LBD-M3  | Monochrome, 3M byte built-in memory, compatible with optional OS |
| A951GOT-Q<br>(Built-in bus communication interface for QCPU (Q mode))             | A951GOT-QTBD    | 256 colors, 1M byte built-in memory                              |
|   | A951GOT-QSBD    | 8 colors, 1M byte built-in memory                                |
|   | A951GOT-QLBD    | Monochrome, 1M byte built-in memory                              |
|   | A951GOT-QTBD-M3 | 256 colors, 3M byte built-in memory, compatible with optional OS |
|   | A951GOT-QSBD-M3 | 8 colors, 3M byte built-in memory, compatible with optional OS   |
|   | A951GOT-QLBD-M3 | Monochrome, 3M byte built-in memory, compatible with optional OS |
| A951GOT<br>(Built-in bus communication interface for A/QnA/Motion controller CPU) | A951GOT-TBD     | 256 colors, 1M byte built-in memory                              |
|   | A951GOT-SBD     | 8 colors, 1M byte built-in memory                                |
|   | A951GOT-LBD     | Monochrome, 1M byte built-in memory                              |
|   | A951GOT-TBD-M3  | 256 colors, 3M byte built-in memory, compatible with optional OS |
|   | A951GOT-SBD-M3  | 8 colors, 3M byte built-in memory, compatible with optional OS   |
|   | A951GOT-LBD-M3  | Monochrome, 3M byte built-in memory, compatible with optional OS |
| A953GOT<br>(Built-in RS-232C communication Interface)                             | A953GOT-TBD     | 256 colors, 1M byte built-in memory                              |
|   | A953GOT-SBD     | 8 colors, 1M byte built-in memory                                |
|   | A953GOT-LBD     | Monochrome, 1M byte built-in memory                              |
|   | A953GOT-TBD-M3  | 256 colors, 3M byte built-in memory, compatible with optional OS |
|   | A953GOT-SBD-M3  | 8 colors, 3M byte built-in memory, compatible with optional OS   |
|   | A953GOT-LBD-M3  | Monochrome, 3M byte built-in memory, compatible with optional OS |
| A956GOT<br>(Built-in communication module Interface)                              | A956GOT-TBD     | 256 colors, 1M byte built-in memory                              |
|   | A956GOT-SBD     | 8 colors, 1M byte built-in memory                                |
|   | A956GOT-LBD     | Monochrome, 1M byte built-in memory                              |
|   | A956GOT-TBD-M3  | 256 colors, 3M byte built-in memory, compatible with optional OS |
|   | A956GOT-SBD-M3  | 8 colors, 3M byte built-in memory, compatible with optional OS   |
|   | A956GOT-LBD-M3  | Monochrome, 3M byte built-in memory, compatible with optional OS |

| Component                       | Type         | Remarks  |
|---------------------------------|--------------|--|
| Bus Connection module           | A7GT-BUSS    | For bus connection, small connector type (For A/QnA/Motion controller CPU)           |
| Multidrop bus connection module | A7GT-BUS2S   | For multidrop bus connection, small connector type (For A/QnA/Motion controller CPU) |
| Protective sheet                | A9GT-50PSC   | Transparent protective sheet for A95 * GOT   |
| Backlight                       | A9GT-50LT    | Backlight for A95 * GOT-SBD, A95 * GOT-LBD   |
| Debug stand                     | A9GT-50STAND | Debug stand for A95 * GOT  |
| Attachment                      | A85GT-95ATT  | For replacement from A85 * GOT to A95 * GOT  |

## (2) List of Components Available for the A956WGOT

| Component                  | Type          | Remarks   |
|----------------------------|---------------|---|
| A956WGOT                   | A956WGOT-TBD  | 256color, 1M byte Built-in memory (Possible to expand to a maximum of 9M bytes by using a memory board), 24VDC          |
| Bus connection board       | A9GT-50WQBUSS | For bus connection, small connector type (For Q (Q mode) CPU)   |
|                            | A9GT-50WBUSS  | For bus connection, small connector type (For A/QnA/Motion controller CPU)  |
| Serial communication board | A9GT-50WRS2   | For Direct connection to CPU/Computer link connection/Microcomputer connection and RS-232C connection                   |
|                            | A9GT-50WRS4   | For Direct connection to CPU/Computer link connection/Microcomputer connection and RS-422 connection                    |
| Protective sheet           | A9GT-50WPSC   | Transparent protective sheet for A956WGOT   |
| Debug stand                | A9GT-50WSTAND | Debug stand for A956WGOT  |
| Compact flash card         | ————          | Commercially available Compact Flash PC card (Compliant with FlashTM)<br>(Compact Flash TM is a trademark of Sun disk.) |
| Memory board               | A9GT-FNB      | Exclusively used for optional OS storage  |
|                            | A9GT-FNB1M    | For optional function OS storage + built-in memory extension, 1M byte   |
|                            | A9GT-FNB2M    | For optional function OS storage + built-in memory extension, 2M byte   |
|                            | A9GT-FNB4M    | For optional function OS storage + built-in memory extension, 4M byte   |
|                            | A9GT-FNB8M    | For optional function OS storage + built-in memory extension, 8M byte   |
|                            | A9GT-QFNB     | Exclusively used for optional OS storage<br>(MELSEC-Q Ladder monitor compatible)  |
|                            | A9GT-QFNB4M   | For optional function OS storage + built-in memory extension, 4M byte<br>(MELSEC-Q Ladder monitor compatible)           |
|                            | A9GT-QFNB8M   | For optional function OS storage + built-in memory extension, 8M byte<br>(MELSEC-Q Ladder monitor compatible)           |

## (3) List of Components Available for the A95\*GOT/A956WGOT

| Component                              | Type          | Remarks   |  |
|--|---------------|---|--|
| Bus Connection module                  | A9GT-BUSSU    | For bus connection, small connector type (For A/QnA/Motion controller CPU)  |  |
| Multidrop bus connection module        | A9GT-QBUS2SU  | For multidrop bus connection, small connector type (For QCPU (Q mode))  |  |
|  | A9GT-BUS2SU   | For multidrop bus connection, small connector type (For A/QnA/Motion controller CPU)  |  |
| Data link module                       | A7GT-J71AP23  | For MELSECNET(II) optical link connection, for use as local station   |  |
|  | A7GT-J71AR23  | For MELSECNET(II) coaxial link connection, for use as local station   |  |
|  | A7GT-J71AT23B | For MELSECNET/B connection, for use as local station  |  |
| Network module                         | A7GT-J71LP23  | For MELSECNET/10 optical loop network connection, for use as ordinary station   |  |
|  | A7GT-J71BR13  | For MELSECNET/10 coaxial bus network connection, for use as ordinary station  |  |
| CC-Link communication module           | A8GT-J61BT13  | For CC-Link connection, for use as intelligent device station   |  |
|  | A8GT-J61BT15  | For CC-Link connection, for use as remote device station  |  |
| Ethernet communication module          | A9GT-J71E71-T | For Ethernet connection   |  |
| External I/O module                    | A8GT-50KBF    | For external I/O equipment connection   |  |
| Numeric keypad panel                   | A8GT-TK       | Data entry Numeric Keypad Panel   |  |
| Memory card interface module           | A1SD59J-MIF   | For PC card loading   |  |
| PC card (SRAM type)                    | _____         | PC card usable on the memory card interface unit (PCMCIA ver.2.1 standard)  |  |
| Printer interface module               | A9GT-50PRF    | For printer connection  |  |
| Printer                                | _____         | Printer compliant with ESC/P24-J84(ESC/P command compatible) *1<br>Hewlett Packard printers (PLC command compatible)                                |  |
| Bar code reader                        | _____         | Names of manufacturer: Token, Opt-electronics, Keyence, Imex, OLYMPUS-symbol, OMRON and DENSO   |  |
| Bus extension connector box            | A9GT-QCNB     | Used for connection of the QCPU (Q mode) long-distance bus.   |  |
| Bus connector conversion box           | A7GT-CNB      | For conversion from large type connector to small type connector<br>(Used for connecting the CPU long-distance bus of the A/QnA Motion controller.) |  |
| Bus connection cable for QCPU (Q mode) | QC06B         | Cable length 0.6m   | For connection between Q base unit and GOT<br>For connection between GOT and GOT |
|  | QC12B         | Cable length 1.2m   |  |
|  | QC30B         | Cable length 3.0m   |  |
|  | QC50B         | Cable length 5.0m   |  |
|  | QC100B        | Cable length 10.0m  |  |
|  | A9GT-QC150BS  | Cable length 15.0m  |  |
|  | A9GT-QC200BS  | Cable length 20.0m  |  |
|  | A9GT-QC250BS  | Cable length 25.0m  |  |
|  | A9GT-QC300BS  | Cable length 30.0m  |  |
|  | A9GT-QC350BS  | Cable length 35.0m  |  |

| Component                   | Type  | Remarks   |
|-----------------------------|---|---|
| Bus connection cable        | AC06B   | Cable length 0.6m   |
|                             | AC12B   | Cable length 1.2m   |
|                             | AC30B   | Cable length 3.0m   |
|                             | AC50B   | Cable length 5.0m   |
|                             | AC12B-R   | Right angle, cable length 1.2m  |
|                             | AC30B-R   | Right angle, cable length 3.0m  |
|                             | AC50B-R   | Right angle, cable length 5.0m  |
|                             | A1SC07B   | Cable length 0.7m   |
|                             | A1SC12B   | Cable length 1.2m   |
|                             | A1SC30B   | Cable length 3.0m   |
|                             | A1SC50B   | Cable length 5.0m   |
|                             | A8GT-C12NB  | Cable length 1.2m   |
|                             | A8GT-C30NB  | Cable length 3.0m   |
|                             | A8GT-C50NB  | Cable length 5.0m   |
|                             | A8GT-C100EXSS   | Cable length 10.0m  |
|                             | A8GT-C200EXSS   | Cable length 20.0m  |
|                             | A8GT-C300EXSS   | Cable length 30.0m  |
|                             | A8GT-C100BS   | Cable length 10.0m  |
|                             | A8GT-C200BS   | Cable length 20.0m  |
|                             | A8GT-C300BS   | Cable length 30.0m  |
| A370C12B                    | Cable length 1.2m   |   |
| A370C25B                    | Cable length 2.5m   |   |
| A9GT-J2C10B                 | Cable length 1.0m   |   |
| RS-422 cable                | AC30R4-25P  | Cable length 3m (D-sub 25-pin at both ends)   |
|                             | AC100R4-25P   | Cable length 10m (D-sub 25-pin at both ends)  |
|                             | AC300R4-25P   | Cable length 30m (D-sub 25-pin at both ends)  |
|                             | ————  | For connection between GOT and computer link module *2  |
| RS-232C cable *3            | QC30R2  | Cable length 3m   |
|                             | AC30R2-9P   | Cable length 3m (D-sub 9-pin, D-sub 25-pin)   |
|                             | AC30R2-9SS  | Cable length 3m (D-sub 9-pin at both ends)  |
|                             | AC30R2  | Cable length 3m (D-sub 25-pin at both ends)   |
|                             | AC30N2A   | Cable length 3m (D-sub 25-pin at both ends)   |
|                             | ————  | For connection between GOT and computer link module *2  |
| ————                        | For connecting the GOT with the power supply unit of the bar code reader *4 |   |
| Printer cable *5            | AC30PIO-20P   | Cable length 3m   |
| Compatible software package | SW *D5C-GTWORKS-E   | Compatible with Microsoft® Windows® 95 operating system, Microsoft® Windows® 98 operating system, Microsoft® Windows NT® Workstation 4.0 operating system |
|                             | SW *D5C-GOTR-PACKE  |   |

\*1 The printer of ESC/P raster specifications such as the PM series cannot be connected and used with the GOT.

\*2 The RS-422/RS-232C cable for use between GOT and computer link module should be fabricated on the user side by referring to the [GOT-A900 Series User's Manual (GT Works Version5/GT Designer Version5 compatible Connection System Manual)].

\*3 The RS-232C cable may be fabricated by the user.

For details of the cable specifications, refer to the [GT Works Version5/GT Designer Version5 Reference Manual].

\*4 Please refer to the [GOT-A900 Series User's Manual (GT Works Version5/GT Designer Version5 compatible Connection System Manual)] and prepare the RS-232C cable between the GOT and the power supply unit of the bar code reader. (Some bar code readers do not need to be connected with the RS-232C cable.)

\*5 The printer cable may be fabricated by the user.

Refer to [A9GT-50PRF type Printer interface module User's Manual] for full information on the specifications needed to fabricate the cable.

## 2.4 Software Packages to be Used

When a GOT is used, a software package of the applicable version or later is required.  
The versions of the software packages required for each GOT are shown below.

| Type              | Compatible software package   |
|-------------------|---|
| A950GOT-TBD(-M3)  | SW0D5C-GTWORKS-E Version A or later, SW4D5C-GOTR-PACKE Version A or later |
| A950GOT-SBD(-M3)  | SW0D5C-GTWORKS-E Version A or later, SW1D5C-GOTRE-PACK Version H or later |
| A950GOT-LBD(-M3)  |   |
| A951GOT-QTBD(-M3) | SW0D5C-GTWORKS-E Version A or later, SW4D5C-GOTR-PACKE Version A or later |
| A951GOT-QSBD(-M3) | SW0D5C-GTWORKS-E Version A or later, SW3D5C-GOTRE-PACK Version C or later |
| A951GOT-QLBD(-M3) |   |
| A951GOT-TBD(-M3)  | SW0D5C-GTWORKS-E Version A or later, SW4D5C-GOTR-PACKE Version A or later |
| A951GOT-SBD(-M3)  | SW0D5C-GTWORKS-E Version A or later, SW1D5C-GOTRE-PACK Version H or later |
| A951GOT-LBD(-M3)  |   |
| A953GOT-TBD(-M3)  | SW0D5C-GTWORKS-E Version A or later, SW4D5C-GOTR-PACKE Version A or later |
| A953GOT-SBD(-M3)  | SW0D5C-GTWORKS-E Version A or later, SW1D5C-GOTRE-PACK Version H or later |
| A953GOT-LBD(-M3)  |   |
| A956GOT-TBD(-M3)  | SW0D5C-GTWORKS-E Version A or later, SW4D5C-GOTR-PACKE Version A or later |
| A956GOT-SBD(-M3)  | SW0D5C-GTWORKS-E Version A or later, SW1D5C-GOTRE-PACK Version H or later |
| A956GOT-LBD(-M3)  |   |
| A956WGOT-TBD      | SW5D5C-GTWORKS-E Version K or later, SW5D5C-GOTR-PACKE Version K or later |

## 2.5 Unusable Conventional Products

The following conventional products cannot be used with this GOT.

| Component                      | Type  |
|--------------------------------|---|
| Bus connection board           | A9GT-BUSS, A9GT-BUS2S   |
| Bus connection module          | A7GT-BUS, A9GT-BUS2   |
| Serial communication board     | A9GT-RS2, A9GT-RS4  |
| Serial communication module    | A8GT-RS2, A8GT-RS4  |
| Backlight                      | A9GT-70LTT, A9GT-70LTS, A9GT-70LTTB, A9GT-80LTT, A8GT-70LTT, A8GT-70LTS, A8GT-50LT  |
| Ladder monitoring cassette     | A8GT-MCAM   |
| Extension memory cassette      | A8GT-MCA1MFDW, A8GT-MCA2MFDW, A8GT-MCA3MFDW   |
| Extension memory board         | A9GT-FNB, A9GT-FNB1M, A9GT-FNB2M, A9GT-FNB4M  |
| Protective sheet               | A9GT-80PSC, A9GT-80PSCL, A9GT-70PSC, A9GT-70PSCL, A9GT-60PSC, A9GT-60PSCL, A8GT-70PSCE, A8GT-70PSNE, A8GT-70PSCS, A8GT-70PSNS, A8GT-50PSC, A8GT-50PSN |
| Printer interface module       | A8GT-70PRF, A8GT-50PRF  |
| External I/O module            | A9GT-70KBF, A8GT-70KBF  |
| Debug stand                    | A9GT-80STAND, A9GT-70STAND, A8GT-70STAND, A8GT-50STAND  |
| Option module mounting fixture | A8GT-50STE  |



## 2.6 Notes on Q4ARCPU Duplex System

This section describes the notes on the connecting of the Q4ARCPU with the GOT, as follows:

## (1) Notes on the additional base for duplex system at the final stage:

To connect the duplex system with the GOT via the bus, connect the GOT with the additional base for duplex system (A68RB) that is provided at the final stage of the duplex system. To use the additional base for duplex system, please apply that of the Version B or after.

- In the following configurations the GOT will not operate normally as specified.
  - (a) The configuration in which the GOT is connected with the fundamental base for the duplex system (A32RB, A33RB) is connected via the bus.
  - (b) The configuration in which the GOT is connected with the additional base (A68RB) for duplex system of Version A is connected via the bus.
- To check and confirm the version of the additional base for duplex system, please refer to the DATE column on the rating plate that is adhered to the part as shown in the illustration below.

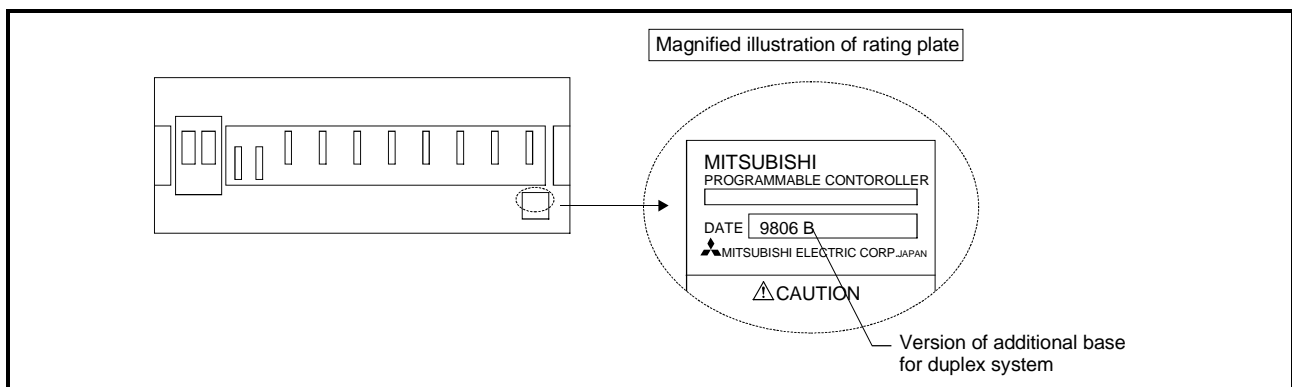

## (2) Notes on 5V DC supply for the additional base (A68RB) for duplex system at the final stage:

220mA of current to be consumed will be supplied from the additional base for duplex system at the final stage to the GOT bus interface, if the GOT power supply is off and the power supply for the power supply module mounted on the additional base for duplex system at the final stage is on. Therefore, please make sure that the 5V DC consumption (8A) of the power supply module will not be exceeded by the sum of the value of the current consumption of the input/output module and special function module that are mounted on the additional base for duplex system at the final stage and the value of the current consumption (220mA) of the GOT bus interface.

## 3 PERFORMANCE

## 3.1 General Specifications

The general specifications of the GOT are indicated below.

| Item                          | Specifications   |  |              |                      |           |  |
|-------------------------------|--|--|--------------|----------------------|-----------|--|
| Operating ambient temperature | Display section  | A95 *GOT: 0 to 40 °C<br>A956WGOT: 0 to 55 °C |              |                      |           |  |
|                               | Other than display section   | 0 to 55 °C                                   |              |                      |           |  |
| Storage ambient temperature   | -20 to 60 °C   |  |              |                      |           |  |
| Operating ambient humidity    | 10 to 90 % RH, non-condensing  |  |              |                      |           |  |
| Storage ambient humidity      | 10 to 90 % RH, non-condensing  |  |              |                      |           |  |
| Vibration resistance          | Conforms to JIS B3501 and IEC 61131-2  |  | Frequency    | Acceleration         | Amplitude | Sweep Count  |
|                               |  | In case of intermittent vibration            | 10 to 57 Hz  | —                    | 0.075 mm  | 10 times in each of X, Y and Z directions (for 80 minutes) |
|                               |  |  | 57 to 150 Hz | 9.8 m/s <sup>2</sup> | —         |  |
|                               |  | In case of continuous vibration              | 10 to 57 Hz  | —                    | 0.035 mm  |  |
| 57 to 150 Hz                  | 4.9 m/s <sup>2</sup>   |  | —            |                      |           |  |
| Shock resistance              | Conforms to JIS B3501, IEC 61131-2 (147 m/s <sup>2</sup> , 3 times in each of X, Y and Z directions) |  |              |                      |           |  |
| Operating atmosphere          | No corrosive gas   |  |              |                      |           |  |
| Operating altitude            | 2000 m(6562 ft) max.   |  |              |                      |           |  |
| Installation site             | Inside control box   |  |              |                      |           |  |
| Overvoltage category *1       | II or less   |  |              |                      |           |  |
| Contamination level *2        | 2 or less  |  |              |                      |           |  |

\*1: Indicates the element in the distribution system between the public electricity grid and the mechanical equipment inside the premises that the relevant device is assumed to be connected to.

Category II applies to devices such as those that draw their power supply from fixed installations.

The surge voltage withstand capability of devices with ratings up to 300V is 2,500V.

\*2: This index gives a measure of the incidence of conductive materials in the environment in which the device is used.

A contamination level of 2 indicates an environment in which there is only contamination by non-conducting materials, but due to occasional condensation, conductivity may occur.

\*3: Please do not use or store GOT in an environment with atmospheric pressure greater than the atmospheric pressure at sea level (0m).

There is a possibility errors may occur if this point is not observed.

## 3.2 Performance Specifications

1) The performance specifications of the A951GOT-Q are shown below.

| Item   |  | Specifications   |
|--|--|--|
|  |  | A951GOT-QTBD(-M3)<br>A951GOT-QSBD(-M3)<br>A951GOT-QLBD(-M3)  |
| Display section  | Type   | TBD(-M3): TFT color liquid crystal SBD(-M3): STN color liquid crystal<br>LBD(-M3): monochrome liquid crystal   |
|  | Screen size [inch] (cm)                            | 6 (15)   |
|  | Resolution [dots]                                  | 320 × 240  |
|  | Display size [mm] [inch]                           | 115 (4.5) × 86 (3.4)   |
|  | Display color [color]                              | TBD(-M3): 256 SBD(-M3): 8 LBD(-M3): 2 (monochrome)   |
| Touch panel  | Number of touch keys [points]                      | 600 (15 lines × 40 columns)  |
|  | Key size [dots]                                    | Minimum 16 × 16 (per key)  |
|  | Repeat function                                    | No   |
| Memory *1  | Type   | Flash ROM  |
|  | Application  | For monitor screen data storage, for OS storage  |
|  | Capacity   | 1M byte built-in (user area) (-M3 has 3M bytes and is compatible with optional OS)   |
| Reference value for data transmission time (For RS-232C communication) |  | When installing OS: 640 to 760 seconds (For basic functions, BUS driver and system monitor (approx. 1.3Mbytes))<br>When downloading screen data: 330 to 570 seconds (For approx. 30 screens (approx. 600kbytes)) |
| Interface Built into main unit   |  | Bus communication interface for QCPU (Q mode) 1 channel  |
| Option module interface  |  | for option module loading, 1 channel   |
| RS-232C interface  |  | For connection of personal computer, for bar-code reader connection, 1 channel   |
| Buzzer output  |  | Single tone (tone length adjustable)   |
| Backlight  |  | Cold cathode fluorescent tube backlight (Backlight OFF/screen saving time setting allowed)   |
| Life *2  | Display section [h] *3                             | 50,000 (Operating ambient temperature: 25°C)   |
|  | Backlight [h]                                      | TBD(-M3): 50,000 SBD/LBD(-M3): 40,000<br>(Time when display luminance reaches 50% at the operating ambient temperature of 25°C)  |
|  | Touch key  | 1 million times or more (operating force 0.98N max.)   |
|  | Built-in memory                                    | Number of write times: 100,000 times   |
| Environmental protective structure                                     | Equivalent to IP65F (front section)                | Hardware Version A or later  |
|  | Equivalent to IP65F /IP67F / NEMA4 (front section) | Hardware Version L (May, 2001) or later  |
| Outline dimensions [mm] (inch)   |  | TBD(-M3) : 164.5 (6.48) (W) × 136 (5.35) (H) × 65 (2.56) (D)<br>SBD/LBD(-M3): 164.5 (6.48) (W) × 136 (5.35) (H) × 57 (2.24) (D)  |
| Panel cutting dimensions [mm] (inch)                                   |  | 156 (6.14) (W) × 123.5 (4.86) (H)  |
| Weight [kg] (lb)   |  | TBD(-M3): 0.71 (1.56) SBD/LBD(-M3): 0.67 (1.47)  |
| Compatible software package  |  | TBD(-M3) : SW0D5C-GTWORKS-E Version A or later, SW4D5C-GOTR-PACKE Version A or later<br>SBD/LBD(-M3): SW0D5C-GTWORKS-E Version A or later, SW3D5C-GOTRE-PACK Version C or later                                  |

\*1 The built-in memory is ROM which allows old data to be overwritten by new data. (Data backup power supply is not needed.)

\*2 Only the backlight of the SBD/LBD(-M3) is replaceable.

When parts must be changed, consult your sales representative.

\*3 The screen save and back light OFF functions of the GOT are used to prevent the display of the screen from being printed and prolong the service life of the back light, respectively.

2) The performance specifications of the A950/951/953/956GOT are shown below.

| Item   |   | Specifications   |  |  |  |
|--|---|--|--|--|--|
|  |   | A950GOT-TBD(-M3)<br>A950GOT-SBD(-M3)<br>A950GOT-LBD(-M3)   | A951GOT-TBD(-M3)<br>A951GOT-SBD(-M3)<br>A951GOT-LBD(-M3) | A953GOT-TBD(-M3)<br>A953GOT-SBD(-M3)<br>A953GOT-LBD(-M3) | A956GOT-TBD(-M3)<br>A956GOT-SBD(-M3)<br>A956GOT-LBD(-M3) |
| Display section  | Type  | TBD(-M3): TFT color liquid crystal    SBD(-M3): STN color liquid crystal<br>LBD(-M3): monochrome liquid crystal  |  |  |  |
|  | Screen size [inch] (cm)                           | 6 (15)   |  |  |  |
|  | Resolution [dots]                                 | 320 × 240  |  |  |  |
|  | Display size [mm] [inch]                          | 115 (4.5) × 86 (3.4)   |  |  |  |
|  | Display color [color]                             | TBD(-M3): 256    SBD(-M3): 8    LBD(-M3): 2 (monochrome)   |  |  |  |
| Touch panel  | Number of touch keys [points]                     | 600 (15 lines × 40 columns)  |  |  |  |
|  | Key size [dots]                                   | Minimum 16 × 16 (per key)  |  |  |  |
|  | Repeat function                                   | No   |  |  |  |
| Memory *1  | Type  | Flash ROM  |  |  |  |
|  | Application                                       | For monitor screen data storage, for OS storage  |  |  |  |
|  | Capacity  | 1M byte built-in (user area) (-M3 has 3M bytes and is compatible with optional OS)   |  |  |  |
| Reference value for data transmission time (For RS-232C communication) |   | When installing OS: 640 to 760 seconds (For basic functions, BUS driver and system monitor (approx. 1.3Mbytes))<br>When downloading screen data: 330 to 570 seconds (For approx. 30 screens (approx. 600kbytes)) |  |  |  |
| Interface Built into main unit   |   | For RS-422 communication<br>1 channel  | For bus communication<br>1 channel                       | For RS-232C communication<br>1 channel                   | For communication module mounting<br>1 channel           |
| Option module interface  |   | for option module loading, 1 channel   |  |  |  |
| RS-232C interface  |   | For connection of personal computer, for bar-code reader connection, 1 channel   |  |  |  |
| Buzzer output  |   | Single tone (tone length adjustable)   |  |  |  |
| Backlight  |   | Cold cathode fluorescent tube backlight (Backlight OFF/screen saving time setting allowed)   |  |  |  |
| Life *2  | Display section [h] *3                            | 50,000 (Operating ambient temperature: 25°C)   |  |  |  |
|  | Backlight [h]                                     | TBD(-M3): 50,000    SBD/LBD(-M3): 40,000<br>(Time when display luminance reaches 50% at the operating ambient temperature of 25°C)   |  |  |  |
|  | Touch key   | 1 million times or more (operating force 0.98N max.)   |  |  |  |
|  | Built-in memory                                   | Number of write times: 100,000 times   |  |  |  |
| Environmental protective structure                                     | Equivalent to IP65F (front section)               | Hardware Version A or later  |  |  |  |
|  | Equivalent to IP65F /IP67F/ NEMA4 (front section) | Hardware Version L (May, 2001) or later  |  |  | Hardware Version K (May, 2001) or later                  |
| Outline dimensions [mm] (inch)   |   | TBD(-M3) : 164.5 (6.48) (W) × 136 (5.35) (H) × 65 (2.56) (D)<br>SBD/LBD(-M3): 164.5 (6.48) (W) × 136 (5.35) (H) × 57 (2.24) (D)  |  |  |  |
| Panel cutting dimensions [mm] (inch)                                   |   | 156 (6.14) (W) × 123.5 (4.86) (H)  |  |  |  |
| Weight [kg] (lb)   |   | TBD(-M3): 0.71 (1.56)    SBD/LBD(-M3): 0.67 (1.47)   |  |  |  |
| Compatible software package  |   | TBD(-M3) : SW0D5C-GTWORKS-E Version A or later, SW4D5C-GOTR-PACKE Version A and above<br>SBD/LBD(-M3): SW0D5C-GTWORKS-E Version A or later, SW1D5C-GOTRE-PACK Version H and above                                |  |  |  |

\*1 The built-in memory is ROM which allows old data to be overwritten by new data. (Data backup power supply is not needed.)

\*2 Only the backlight of the SBD/LBD(-M3) is replaceable.  
When parts must be changed, consult your sales representative.

\*3 The screen save/back light OFF functions of the GOT are used to prevent the display of the screen from being printed and prolong the service life of the back light, respectively.

3) The performance specifications of the A956WGOT are shown below.

| Item   |                               | Specifications   |
|--|-------------------------------|--|
|  |                               | A956WGOT-TBD   |
| Display section<br>*1<br>*2<br>*3                                      | Type                          | TFT color liquid crystal   |
|  | Screen size [Inch] (cm)       | 7 (18)   |
|  | Resolution [dots]             | 480 × 234  |
|  | Display size [mm] (inch)      | 155.52 (6.12) × 87.75 (3.45)   |
|  | Display color [color]         | 256  |
| Touch panel  | Number of touch keys [points] | 450 (15 lines × 30 columns)  |
|  | Key size [dots]               | Minimum 16 × 16 (per key), (8 × 16 only for bottom line)   |
|  | Repeat function               | No   |
| Memory<br>*4   | Type                          | Flash ROM  |
|  | Application                   | For monitor screen data storage, for OS storage  |
|  | Capacity                      | 1M byte built-in (user area), max. 8M bytes increasable  |
| Reference value for data transmission time (For RS-232C communication) |                               | When installing OS: 640 to 760 seconds (For basic functions, BUS driver and system monitor (approx. 1.3Mbytes))<br>When downloading screen data: 330 to 570 seconds (For approx. 30 screens (approx. 600kbytes)) |
| Communication board slot*5   |                               | For communication board loading, 1 slot  |
| Communication module interface*5                                       |                               | For communication module loading, 1 channel  |
| Option module interface  |                               | For option module loading, 1 channel   |
| Compact flash card interface   |                               | For Compact flash card loading, 1 channel  |
| Memory board slot  |                               | For memory board loading, 1 slot   |
| RS-232C interface  |                               | For connection of personal computer, for bar-code reader connection, 1 channel   |
| Buzzer output  |                               | Single tone (tone length adjustable)   |
| Backlight  |                               | Cold cathode fluorescent tube backlight (Backlight OFF/screen saving time setting allowed)   |
| Life *6  | Display section [h]<br>*7     | 50,000 (Operating ambient temperature: 25°C)   |
|  | Backlight [h]*7               | 50,000<br>(Time when display luminance reaches 50% at the operating ambient temperature of 25°C)   |
|  | Touch key                     | 1 million times or more (operating force 0.98N max.)   |
|  | Built-in memory               | Number of write times: 100,000 times   |
| Environmental protective structure                                     |                               | Equivalent to IP65F (front section)  |
| Outline dimensions [mm] (inch)   |                               | 215 (8.46) (W) × 133 (5.24) (H) × 70.8 (2.79) (D)  |
| Panel cutting dimensions [mm] (inch)                                   |                               | 205.5 (8.09) (W) × 123.5 (4.86) (H)  |
| Weight [kg] (lb)   |                               | 1.05 (2.31)  |
| Compatible software package  |                               | SW5D5C-GTWORKS-E Version K or later, SW5D5C-GOTR-PACKE Version K or later  |

\*1 If you run the monitor with A956WGOT, the screen may flicker depending on the type of object/shape fill pattern used when creating images.

This is due to the specifications of the LCD panel and is not a malfunction.

Be sure to check the combination of the type of pattern and color on the machine before using.

For patterns likely to flicker and countermeasures against flickers, refer to GT Works Version5/GT Designer Version5 Reference Manual.

\*2 Depending on the display color combination, the visibility of the screen may be lower from certain viewpoints.

Before using, check the color combination with the machine installed in the usage environment.

By designating bright colors for the basic color types, you can decrease the chances of this phenomenon occurring.

\*3 With the LCD panel, situations with luminous points (points that stay lit up) and dark points (points that do not light up) may occur.

This is a feature of the LCD panel and is not a malfunction.

- \*4 The built-in FLASH ROM memory allows old data be overwritten by new data. (Data backup power supply is not needed.)
- \*5 Note that either of the communication board slot and communication module interface may only be used.
- \*6 The A956WGOT backlight cannot be replaced by the user.
- \*7 When parts must be changed, consult your sales representative.
- \*8 The screen saving/back light OFF function of GOT is extended, thus reducing burn-in of the display panel and extending longevity of the back light.

### 3.3 Power Supply Specifications

| Item   | Specifications   |         |          |
|--|--|---------|----------|
|  | A950GOT, A951GOT-Q, A951GOT, A953GOT   | A956GOT | A956WGOT |
| Input power supply voltage   | 24VDC (+10%, -15%)   |         |          |
| Input max. power [W]   | 12   | 16      | 22       |
| Inrush current [A]   | 40 max. (30VDC, max. load)   |         |          |
| Permissible instantaneous power failure time [ms]                        | 1(19.2VDC or more)   |         |          |
| Noise immunity   | By noise simulator of 500Vp-p noise volatage, 1 $\mu$ s noise width and 25 to 60Hz noise frequency |         |          |
| Dielectric withstand voltage   | 500VAC for 1 minute across DC external terminals and earth   |         |          |
| Insulation resistance  | 10M $\Omega$ or larger by insulation resistance tester   |         |          |
| Applicable wire size [mm <sup>2</sup> ]                                  | 0.75 to 2  |         |          |
| Applicable solderless terminal   | RAV1.25-3, V2-S3.3, V2-N3A, FV2-N3A  |         |          |
| Applicable tightening torque [N • cm]<br>(Terminal block terminal screw) | 59 to 88   |         |          |

#### Remarks

Please note that resetting will take place if an instantaneous power failure occurs to the GOT power supply.

However, the monitoring and other functions operate normally if the instantaneous power failure time is within 1ms.

4 NAMES OF THE PARTS AND THEIR SETTINGS

(1) Names of the Parts and Their Settings of the A95\*GOT are indicated below.

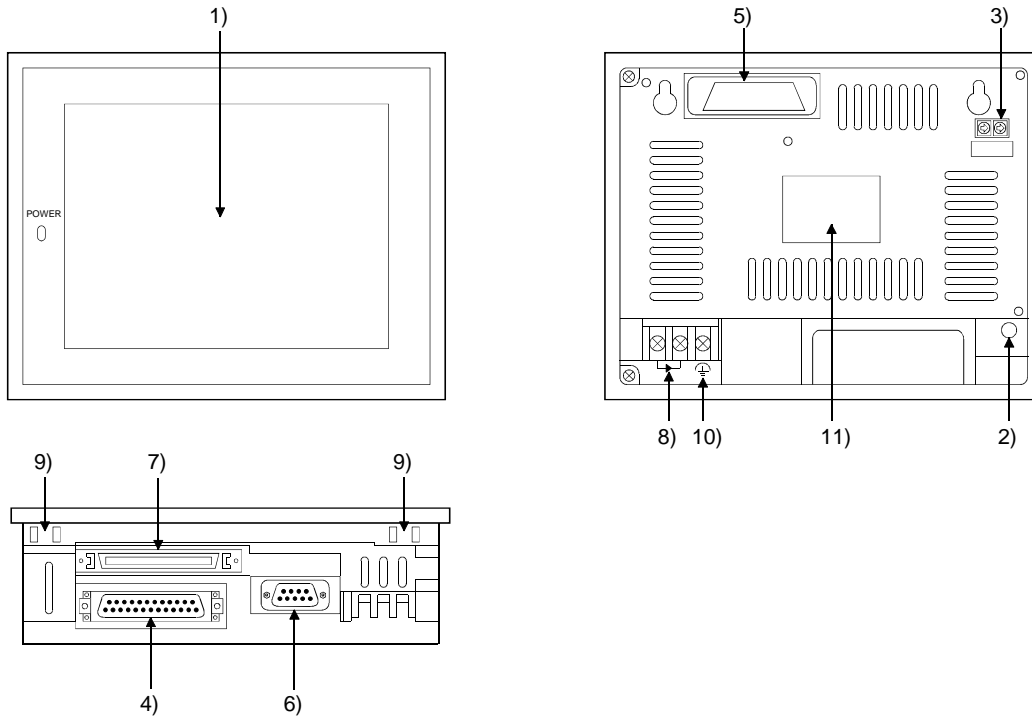

4

| No. | Name   | Description   |
|-----|--|---|
| 1)  | Display section  | Shows the screen  |
| 2)  | Reset button   | Used to reset the hardware of the GOT (invalid for bus connection)  |
| 3)  | Extension number setting switch, (A951GOT only)              | Used to set the extension number for GOT assignment<br>1 to 7 : Extension number<br>8, 9, 0: Must not be used |
|     | I/O slot setting switch (A951GOT only)                       | Used to set the I/O slot number for GOT assignment<br>0 to 7: I/O slot number<br>8, 9 : Must not be used      |
| 4)  | RS-422 communication interface (A950GOT only)                | For RS-422 communication connection   |
|     | Bus communication interface for QCPU (Q mode) (A951GOT only) | For bus connection cable connection (For QCPU (Q mode))   |
|     | Bus communication interface (A951GOT only)                   | For bus communication cable connection (For A/QnA/Motion controller CPU)                                      |
|     | RS-232C communication interface (A953GOT only)               | For RS-232C communication cable connection  |
| 5)  | Communication module interface (A956GOT only)                | Interface for loading the communication module  |
| 6)  | RS-232C interface  | For connection of personal computer<br>For connecting the bar code reader                                     |
| 7)  | Option module interface                                      | For connection Printer I/F module, Memory card I/F module, External I/O module                                |
| 8)  | Terminal block   | For power input   |
| 9)  | Mounting fixture fitting portion                             | For mounting fixture fitting  |
| 10) | Ground terminal  | For earthing (For safety, please make sure to ground this terminal.)  |
| 11) | Rating plate   |   |

(2) Names of the Parts and Their Settings of the A956WGOT are indicated below.

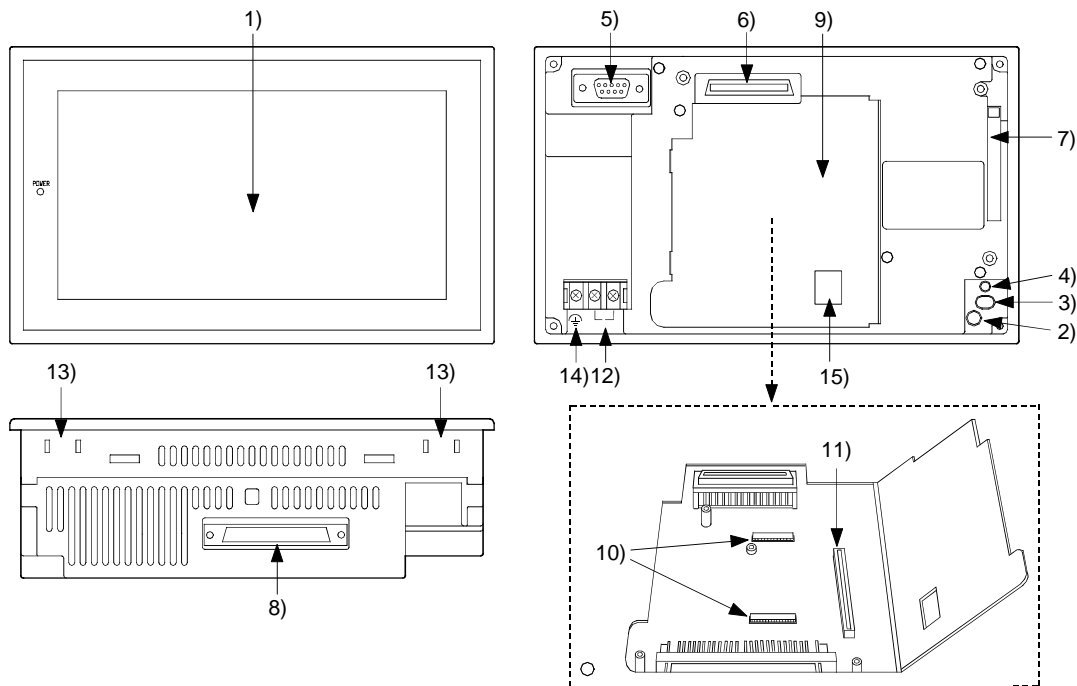

4

| No. | Name  | Description   |
|-----|---|---|
| 1)  | Display section                                       | Shows the screen  |
| 2)  | Reset button  | Used to reset the hardware of the GOT (invalid for bus connection)  |
| 3)  | Compact flash card access switch                      | Used to set the condition of access to the compact flash card when it is loaded during power-on (Factory-set to OFF)<br>OFF :Access from GOT to compact flash card inhibited<br>ON :Access from GOT to compact flash card enabled<br>(When a memory card interface unit is used, a compact flash card cannot be used. Therefore, turn this switch OFF.) |
| 4)  | Compact flash card LED                                | Indicates whether the compact flash card may be loaded/unloaded or not<br>OFF :Compact flash card may be loaded/unloaded<br>(When switch 3 is OFF)<br>ON :Compact flash card must not be loaded/unloaded<br>(When switch 3 is ON)   |
| 5)  | RS-232C interface                                     | For connection of personal computer<br>For connecting the bar code reader   |
| 6)  | Communication module interface                        | Interface for communication module loading  |
| 7)  | Compact flash card slot                               | Slot for Compact flash card loading   |
| 8)  | Option module interface                               | For connection Printer I/F module, Memory card I/F module, External I/O module  |
| 9)  | Slot cover  | Cover of the memory board slot and the communication board slot   |
| 10) | Memory board slot                                     | Slot for memory board loading   |
| 11) | Communication board slot                              | Slot for communication board loading  |
| 12) | Terminal block  | For power input   |
| 13) | Mounting fixture fitting portion                      | For mounting fixture fitting  |
| 14) | Ground terminal                                       | For earthing (For safety, please make sure to ground this terminal.)  |
| 15) | Bus connection board setting switch confirmation hole | For confirming the extension number of the I/O slot number set with the bus connection board<br>(If you are not using the A9GT-50WBUSS, it is possible to attach the seal included with the GOT main unit to cover the hole.)   |



## 5 ROUGH PRE-OPERATION PROCEDURE

This chapter gives a rough procedure to be performed before starting the operation of the GOT.

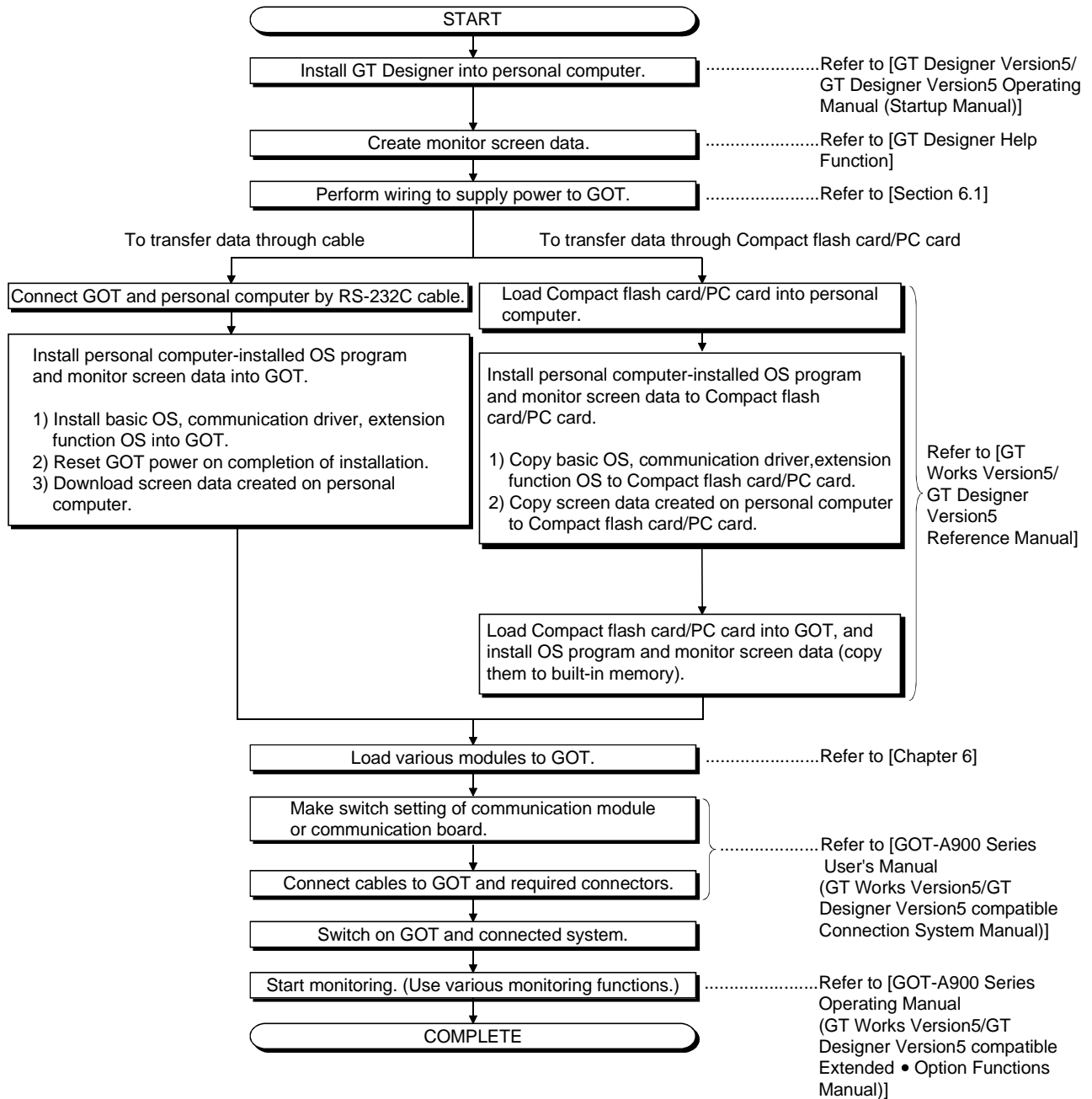



## 6 HANDLING

This chapter explains how to handle the GOT main unit and components.

### 6.1 GOT Main Unit

#### 6.1.1 Handling instructions

This section describes the instructions for handling the GOT main unit and components.

#### DANGER

- Before installing or removing the GOT main unit to or from an enclosure, always turn the GOT power OFF before installing or removing the GOT main unit to or from an enclosure.  
Not doing so can cause a module failure or malfunction
- Before loading or unloading the communication module, communication board, external I/O interface module or memory card interface module to or from the GOT, always turn the GOT power OFF before loading or unloading the communication module, external I/O interface module or memory card interface module to or from the GOT.  
Not doing so can cause a module failure or malfunction.
- Before starting wiring, always turn the GOT power OFF before starting wiring.  
Not doing so may cause an electric shock, product damage or malfunction.

## 6

#### CAUTION

- The GOT should be used in the environment given in the general specifications of this user's manual.  
Not doing so can cause an electric shock, fire, malfunction or product damage or deterioration.
- When mounting the GOT main unit to an enclosure, tighten the mounting screws in the specified torque range.  
Undertightening can cause a drop, short circuit or malfunction.  
Overtightening can cause a drop, short circuit or malfunction due to the damage of the screws or module.
- When loading the communication module to the GOT main unit, fit it to the connection interface of the GOT and tighten the mounting screws in the specified torque range.  
Undertightening can cause a drop, failure or malfunction.  
Overtightening can cause a drop, failure or malfunction due to the damage of the screws or module.
- Please make sure to ground FG terminal of the GOT power supply unit by applying Class D Grounding (Class 3 Grounding) Method or higher which is used exclusively for the GOT.
- Correctly wire the power supply module on the GOT after confirming the rated voltage and terminal arrangement of the product.  
Not doing so can cause a fire or failure.
- Exercise care to avoid foreign matter such as chips and wire offcuts entering the module.  
Not doing so can cause a fire, failure or malfunction.

|                         |   |
|-------------------------|---|
| <p><b>⚠ CAUTION</b></p> | <ul style="list-style-type: none"> <li>● Tighten the terminal screws of the GOT power supply section in the specified torque range.<br/>Undertightening can cause a short circuit or malfunction.<br/>Overtightening can cause a short circuit or malfunction due to the damage of the screws or module.</li> <li>● Plug the bus connection cable by inserting it into the connector of the connected module until it "clicks".<br/>After plugging, check that it has been inserted snugly.<br/>Not doing so can cause a malfunction due to a contact fault.</li> <li>● Plug the communication cable into the connector of the connected module and tighten the mounting and terminal screws in the specified torque range.<br/>Undertightening can cause a short circuit or malfunction.<br/>Overtightening can cause a short circuit or malfunction due to the damage of the screws or module.</li> <li>● Do not touch the conductive and electronic parts of the module directly.<br/>Doing so can cause a module malfunction or failure.</li> </ul> |
|-------------------------|---|

- (1) Do not drop the module or give it strong impact.  
Doing so can cause a failure because the display device is made of glass.
- (2) Do not remove the printed circuit board of the module from the case.  
Doing so can cause a failure.
- (3) When mounting the main unit to a control box or the like, set the display section as shown below.
  - When the temperature inside the enclosure is 40 to 55°C or less, the mounting angle should be in the range 60 to 105 degrees.

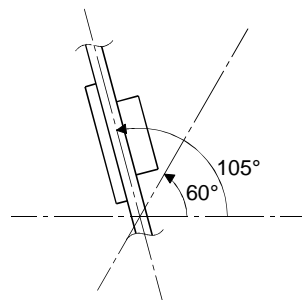
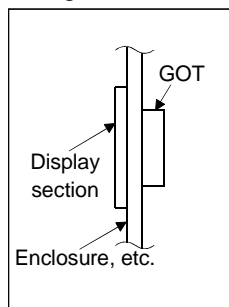

- The GOT will be deteriorated earlier if it is used at the mounting angle other than the above. Therefore, the temperature inside the enclosure should be within 40°C.

- (4) Tighten the screws in the following specified range.

| Screw Location  | Tightening Torque Range |
|---|-------------------------|
| Ground terminal screw (M3 screw)                                | 59 to 88N ● cm          |
| Terminal block terminal screw (M3 screw)                        |                         |
| Module mounting screw (M4 screw)                                |                         |
| Communication board mounting screw (M3 screw)                   | 36 to 48N ● cm          |
| Communication module mounting screw (M3 screw)                  |                         |
| Option module mounting screw (M3 screw)                         |                         |
| Case fixing screw (M3 screw)                                    | 25 to 35N ● cm          |
| Memory board mounting screw (M2.6 screw)                        |                         |
| RS-232C connector mounting screw (#4-40 UNC (inch screw))       | 20 to 28N ● cm          |
| Bus connection cable connector mounting screw for QCPU (Q mode) | 20N ● cm                |

6.1.2 Installation method

This section provides how to install the GOT.

(1) Mounting panel cutting dimensions

When mounting the GOT on a control box door, user-made mounting base or the like, the door or mounting base must be cut as indicated below.

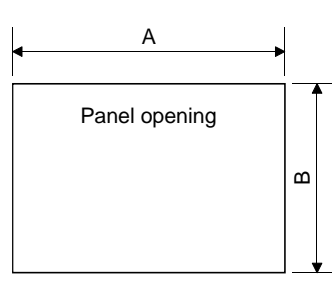

| Type     | A [mm](inch)                            | B [mm](inch)                            |
|----------|---|---|
| A95*GOT  | 156 (6.14)<br>[+1.0 (0.04),<br>-0(0)]   | 123.5 (4.86)<br>[+1.0 (0.04),<br>-0(0)] |
| A956WGOT | 205.5 (8.09)<br>[+1.0 (0.04),<br>-0(0)] | 123.5 (4.86)<br>[+1.0 (0.04),<br>-0(0)] |

(2) Mounting position

When mounting the GOT, the following clearances must be left from the other device.

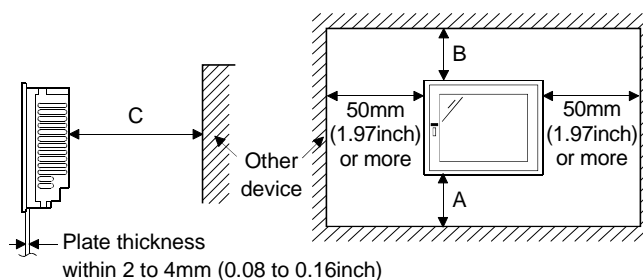

Part A size: Because the connection cable of the GOT is pulled downward, the following space is required according to its radius of curvature.

| Item     | A [mm (inch)]      |
|----------|--------------------|
| A95GOT   | 130 (5.12) or more |
| A956WGOT |                    |

Part B size: Please allow a gap 80mm (3.15inch) or more from the structure and other equipment in the upper part of the unit to often allow good ventilation.

Part C size: When installing devices that generate radiated noise (such as a contactor) or a device that generate heat near the GOT, always leave a clearance of 100mm (3.94inch) or more to the back and 50mm (1.97inch) or more to the left and right to avoid the effects of the noise and heat.

| POINT   |
|---|
| Depending on the type of the cable to be connected to the GOT main body, longer clearances than those specified above may be required.<br>When mounting a GOT, be sure to consider the dimensions of the connector and the cable bend radius. |

(3) Mounting method

- (a) Put the GOT main unit into the panel opening, with its front face first.
- (b) Mount the GOT in the following four locations at its top and bottom.

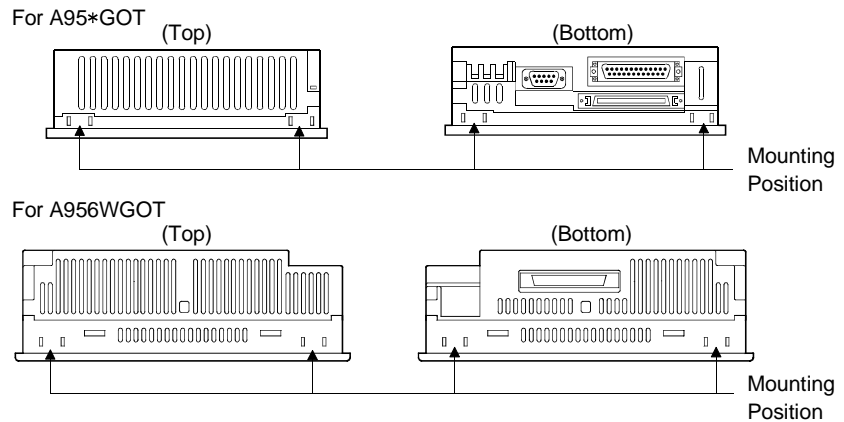

- (c) How to mount and fix the mounting fixture is given below.

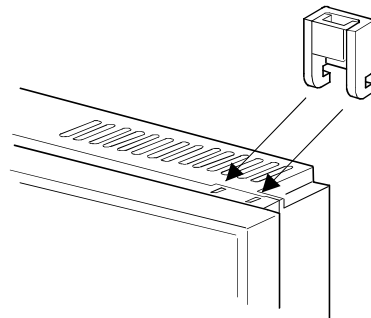

- 1) Insert the mounting fixture into the fixture fitting portion of the GOT main unit.
- 2) Tighten and fix the mounting screw in the specified torque range.

6.1.3 Wiring method

How to wiring the GOT power supply section is explained below.

(1) Wiring diagram of the A95\*GOT

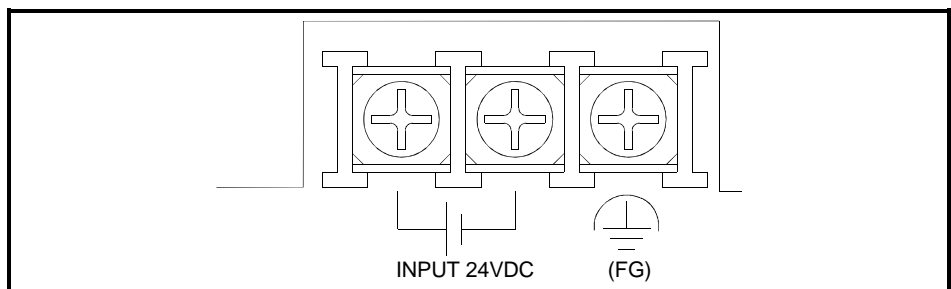

(2) Wiring diagram of the A956WGOT

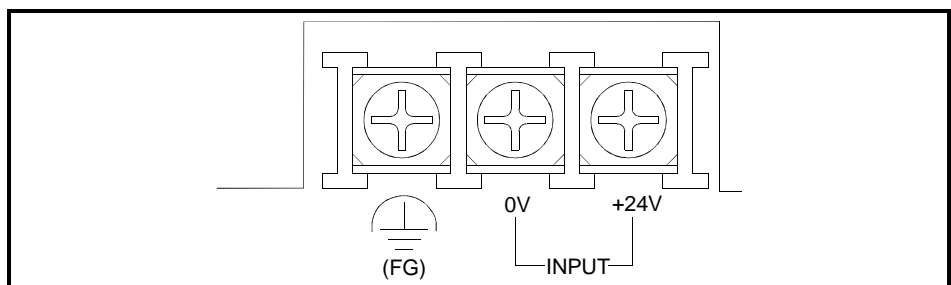

**POINT**

Note that the terminals of the A956WGOT are arranged in the reverse order of the terminals of the A95\*GOT.

6.1.4 Installation of handy type GOT

The A950GOT can be used as a handy type, in addition to the conventional installation method.

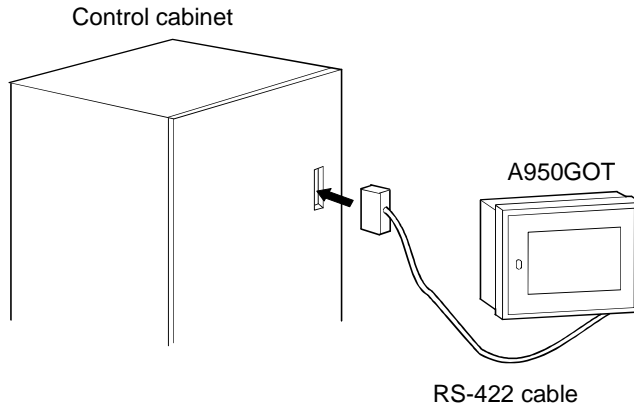

RS-422 cable to connect the GOT and the computer link unit must be prepared by the user.

1) Wiring diagram

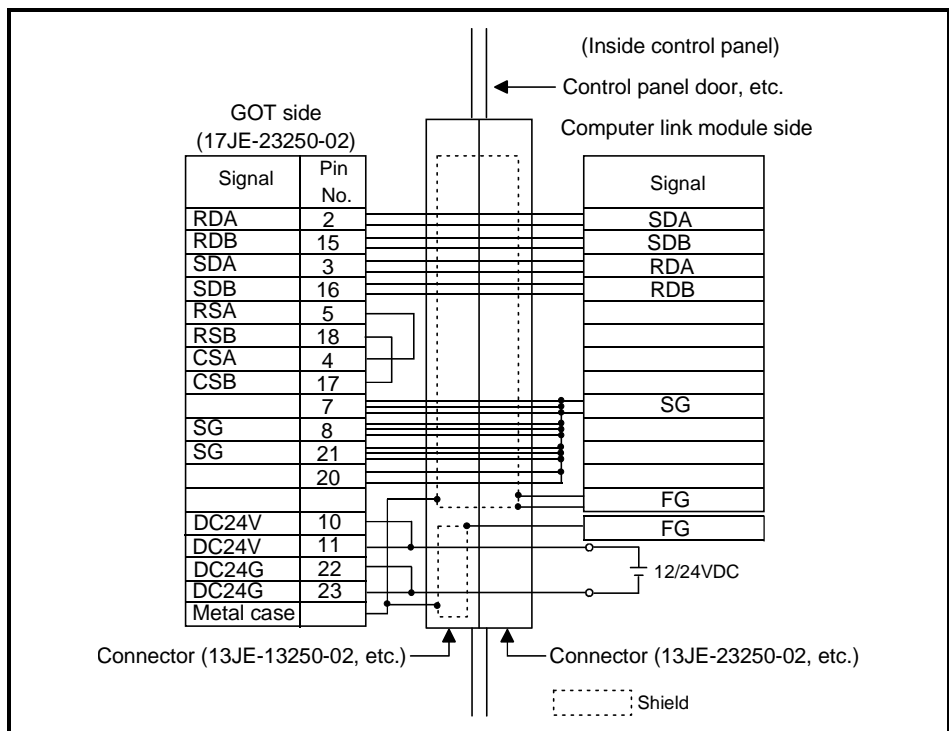

2) An internal diagram of the control panel is shown below.

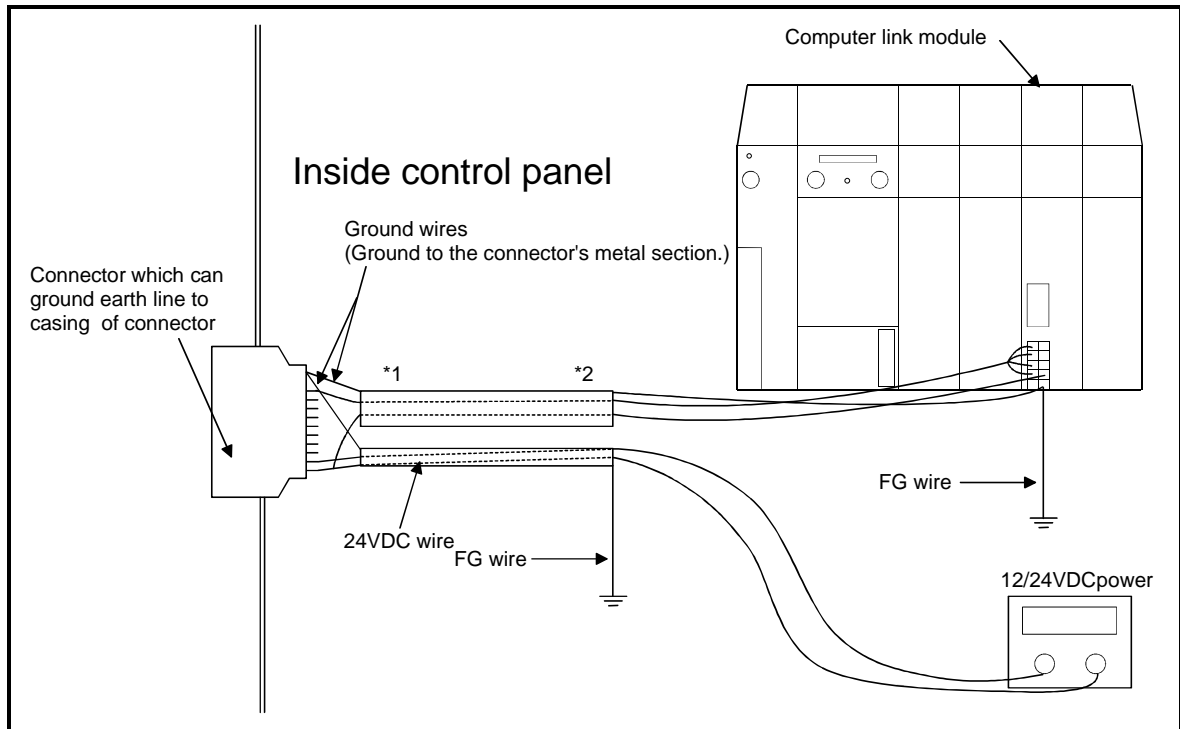

\*1: Separately ground the power wire and signal wire.

\*2: Power wire and the signal wire must be separated by a separate shield and ground to FG.

3) Notes when cable is made.

- The cable must be 200m or shorter.
- When branching inside and outside the control panel, use a connector in between.  
The connector used must be able to attach the earthing to the connector casing.
- When the cable is made, the terminal 24VDC of the connector on the GOT side is connected with the 24VDC power supply of the control board.  
Therefore, it should not be connected to the power supply terminal in the back of the main body of GOT.



## 6.2 Protective Sheet

The protective sheet is used to protect the operation surface from scratches and contamination which may take place when the touch keys of the GOT display section are operated.

### 6.2.1 Protective sheet type

The following protective sheet type is available.

| Type        | Description                               |
|-------------|---|
| A9GT-50PSC  | Transparent protective sheet for A95*GOT  |
| A9GT-50WPSC | Transparent protective sheet for A956WGOT |

### 6.2.2 Mounting procedure

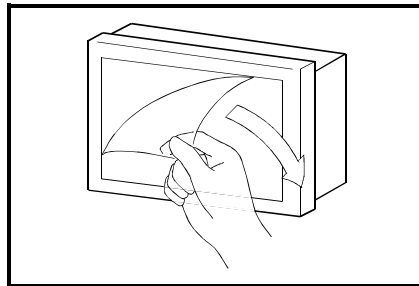

- 1) From the display section of the GOT, peel off the sheet applied before shipment from the factory or the old protective sheet.

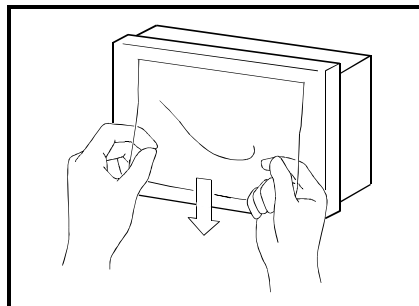

- 2) Peel off the release film of the new protective sheet and apply its adhesive surface to the display section of the GOT. When applying the protective sheet, exercise care not to make it loose and not to make gaps on the adhesive surface.

### 6.3 Memory board (A956WGOT only)

The memory board is used to store the optional function OS program (ladder monitoring function, recipe function, speech output function, etc.) and to increase the built-in memory capacity.

#### 6.3.1 Memory board types

The following memory board types are available.

| Type        | Description   |
|-------------|---|
| A9GT-FNB    | Exclusively used for optional function OS storage   |
| A9GT-FNB1M  | For optional function OS storage + built-in memory extension, 1M byte   |
| A9GT-FNB2M  | For optional function OS storage + built-in memory extension, 2M byte   |
| A9GT-FNB4M  | For optional function OS storage + built-in memory extension, 4M byte   |
| A9GT-FNB8M  | For optional function OS storage + built-in memory extension, 8M byte   |
| A9GT-QFNB   | Exclusively used for optional function OS storage<br>(MELSEC-Q Ladder monitor compatible)                     |
| A9GT-QFNB4M | For optional function OS storage + built-in memory extension, 4M byte<br>(MELSEC-Q Ladder monitor compatible) |
| A9GT-QFNB8M | For optional function OS storage + built-in memory extension, 8M byte<br>(MELSEC-Q Ladder monitor compatible) |

\* When using the ladder monitor function, use the A9GT-QFNB (4/8M).

#### 6.3.2 Mounting procedure

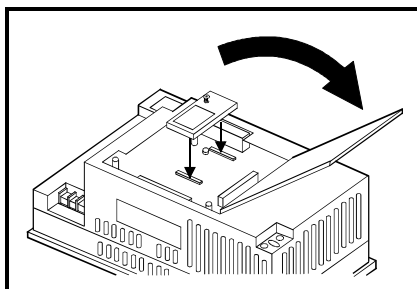

1) Open the slot cover on the back of the A956WGOT

2) Mount the memory board in the slot for mounting a memory board.  
Be careful not to touch the board inside the GOT main body by hand when mounting the memory board.

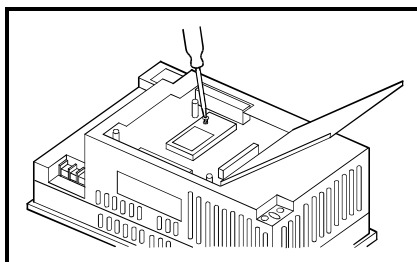

3) Fix by tightening the mounting screws of the memory board within the specified torque range.

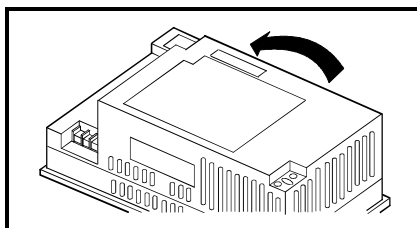

4) Close the slot cover.

## 6.4 Memory Card Interface Module

The memory card interface module is connected to the GOT when the PC card is used with the GOT.

The PC card is used to transfer the OS and monitor screen data and to store the data of the alarm history and recipe functions.

Refer to the GT Works Version5/GT Designer Version5 Reference Manual for details.

### 6.4.1 Memory card interface module type

The following memory card interface module type is available.

| Type        | Description                       |
|-------------|-----------------------------------|
| A1SD59J-MIF | Memory card interface module type |

### 6.4.2 Mounting procedure

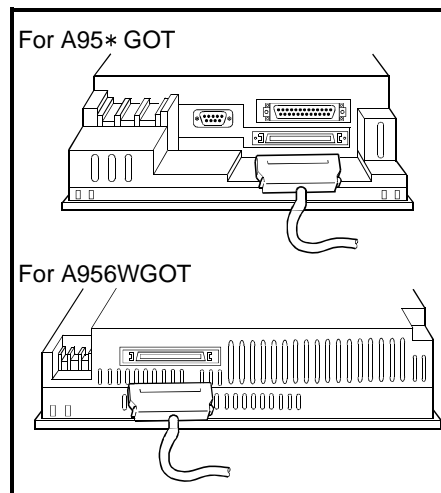

- 1) Install the A1SD59J-MIF to the control cabinet, etc.
- 2) Plug the GOT side connector to the option unit at the bottom of the GOT.

- When a memory card interface unit is used, a compact flash card cannot be used. When using a memory card interface module, turn off the memory card access switch on the A956WGOT main body.

### 6.4.3 PC card types

The PC card usable is any of the PC card having the following specifications (standard) whose operations have been checked by Mitsubishi.

- Commercial SRAM type PC card conforming to PCMCIA ver. 2.1.

### 6.4.4 Battery changing timing and method

#### (1) How to check for battery low

The GOT checks for a battery low of the memory card loaded. (Only when the memory card access switch is ON)

The battery low checking methods are given below.

##### 1) Using the self-diagnostic function to check

When a battery low occurs, the corresponding message appears on the self-diagnostic screen.

For the details, refer to the [GOT-A900 Series Operating Manual (GT Works Version5/GT Designer Version5 compatible Extended ● Option Functions Manual)].

##### 2) Using the alarm list display (system alarm) function to check

When a battery low occurs, the error warning message and battery low error code appear on the monitor screen.

For the details, refer to the [GT Designer Help Function].

#### (2) Battery life

For the PC card backup time, refer to the instruction manual attached to the memory card used.

#### (3) Battery changing

For the PC card battery changing method, refer to the instruction manual attached to the memory card used.

6.4.5 Loading and unloading procedures

The PC card can be loaded/unloaded while power is on. Note that the PC card should be loaded/unloaded after it has been made ready to be loaded/unloaded in the following procedures.

(1) Mounting

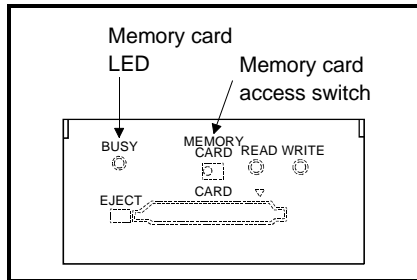

- 1) Set the memory card access switch of the A1SD59J-MIF to "OFF" and make sure that the memory card LED goes off. When the memory card LED goes off, the PC card can be loaded/unloaded while power is on.

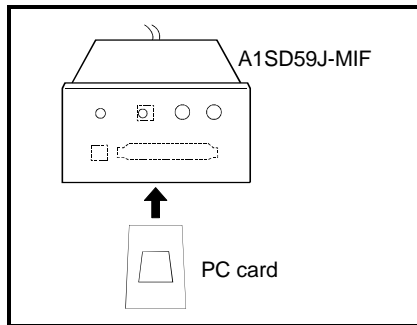

- 2) When loading the PC card into the A1SD59J-MIF, insert and load it into the PC card interface with its top face up.

(2) Dismounting

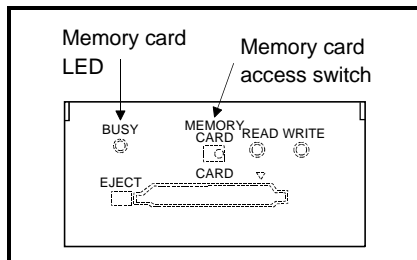

- 1) Set the memory card access switch of the A1SD59J-MIF to "OFF" and make sure that the memory card LED goes off. When the PC card LED goes off, the memory card can be loaded/unloaded while power is on.

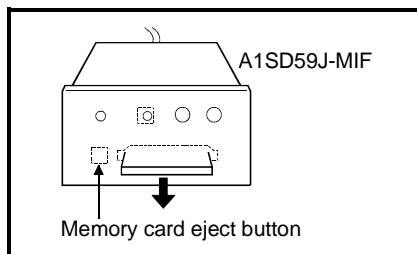

- 2) Remove the PC card after fully pushing the memory card eject button of the A1SD59J-MIF to eject the PC card.

## 6.5 Compact flash card (A956WGOT only)

The Compact flash card is used to transfer the OS and monitor screen data and to store the data of the alarm history and recipe functions.

(ROM\_BIOS cannot be installed with the Compact flash card.)

Refer to the GT Works Version5/GT Designer Version5 Reference Manual for details.

### 6.5.1 Compact flash card types

The Compact flash card usable is any of the Compact flash card having the following specifications (standard) whose operations have been checked by Mitsubishi.

- Commercial Compact flash card conforming to Compact flash™.  
(Compact Flash™ is a trademark of Sun disk.)

### 6.5.2 Loading and unloading procedures

The Compact flash card can be loaded/unloaded while power is on. Note that the Compact flash card should be loaded/unloaded after it has been made ready to be loaded/unloaded in the following procedures.

#### (1) Mounting

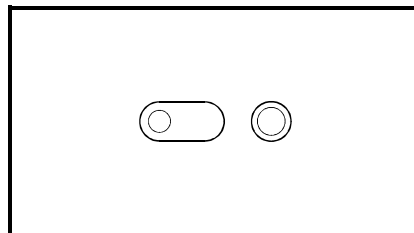

- 1) Set the compact flash card access switch of the GOT to "OFF" and make sure that the compact flash card LED goes off.  
When the compact flash LED goes off, the compact flash card can be loaded/unloaded while power is on.

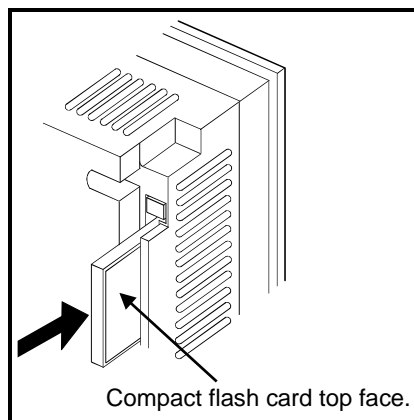

- 2) When loading the compact flash card into the GOT, insert and load it into the compact flash card interface with its top face up.

## (2) Dismounting

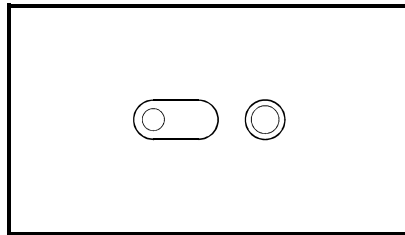

1) Set the compact flash card access switch of the GOT to "OFF" and make sure that the compact flash card LED goes off.

When the compact flash card LED goes off, the compact flash card can be loaded/unloaded while power is on.

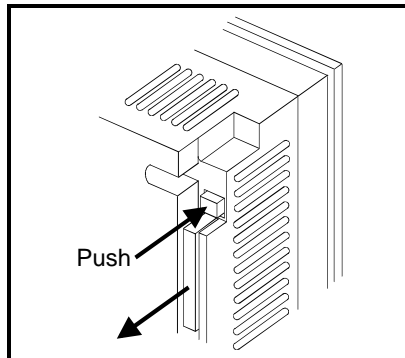

2) Remove the compact flash card after fully pushing the compact flash card ejection button of the GOT to eject the compact flash card.

- When a memory card interface unit is used, a compact flash card cannot be used. When using a memory card interface module, turn off the memory card access switch on the GOT main body.

## 6.6 Communication Board (A956WGOT only)

The communication board is used to make the A956WGOT interface compatible with the system to be connected to.

For the details of the connection form, refer to the [GOT-A900 Series User's Manual (GT Works Version5/GT Designer Version5 compatible Connection System Manual)].

### 6.6.1 Communication board types

The following connection board types are available.

| Type           | Description   |
|----------------|---|
| A9GT-50WQBUISS | For bus connection, small connector type (For QCPU (Q mode))  |
| A9GT-50WBUISS  | For bus connection, small connector type (For A/QnA/Motion controller CPU)                            |
| A9GT-50WRS4    | For Direct connection to CPU/Computer link connection/Microcomputer connection and RS-422 connection  |
| A9GT-50WRS2    | For Direct connection to CPU/Computer link connection/Microcomputer connection and RS-232C connection |

### 6.6.2 Mounting procedure

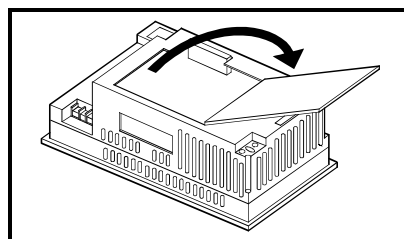

1) Open the slot cover on the back of the A956WGOT.

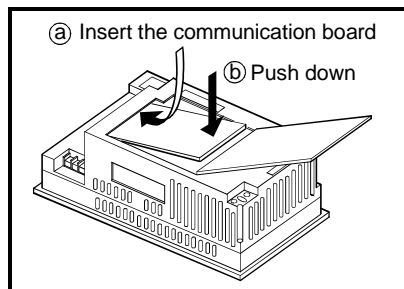

2) Mount the communication board in the slot for mounting a communication board. (Align the hole for the attachment screw on the transmission board with the hole for the attachment screw on the transmission board of the GOT main module, then attach.)

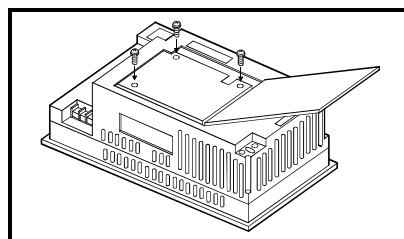

3) Fix by tightening the mounting screws of the communication board within the specified torque range.

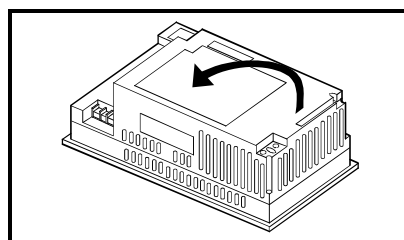

4) Close the slot cover.



## 6.7 Communication Module (A956GOT, A956WGOT Only)

The communication module is used to make the A956GOT, A956WGOT interface compatible with the system to be connected to.

For the details of the connection form, refer to the [GOT-A900 Series User's Manual (GT Works Version5/GT Designer Version5 compatible Connection System Manual)].

### 6.7.1 Connection module types

The following connection module types are available.

| Type           | Description  |
|----------------|--|
| A9GT-QBUS2SU   | For multidrop bus connection, small connector type (For QCPU (Q mode))               |
| A9GT-BUSSU     | For bus connection, small connector type (For A/QnA/Motion controller CPU)           |
| A7GT-BUSS*1*2  |  |
| A9GT-BUS2SU    | For multidrop bus connection, small connector type (For A/QnA/Motion controller CPU) |
| A7GT-BUS2S*1*2 |  |
| A7GT-J71AP23   | For MELSECNET(II) optical link connection, for use as local station                  |
| A7GT-J71AR23   | For MELSECNET(II) coaxial link connection, for use as local station                  |
| A7GT-J71AT23B  | For MELSECNET/B connection, for use as local station                                 |
| A7GT-J71LP23   | For MELSECNET/10 optical loop network connection, for use as ordinary station        |
| A7GT-J71BR13   | For MELSECNET/10 coaxial bus network connection, for use as ordinary station         |
| A8GT-J61BT13   | For CC-Link connection, for use as intelligent device station                        |
| A8GT-J61BT15   | For CC-Link connection, for use as remote device station                             |
| A9GT-J71E71-T  | For Ethernet connection  |

\*1 The A956WGOT cannot be used.

\*2 When using the A7GT-BUSS or A7GT-BUS2S, the module hardware version must be version B or above.

| POINT  |
|--|
| <p>Confirm the hardware version of the unit stamped on the rating plate of the product.</p> <div style="text-align: center;"> <p>MITSUBISHI<br/>A BUS INTERFACE UNIT<br/>MODEL A7GT-BUSS</p> <p>DATE 9905 <b>B</b></p> <p>MITSUBISHI ELECTRIC CORP. JAPAN</p> <p>Hardware version</p> <p>Rating plate</p> </div> |

## 6.7.2 Mounting procedure

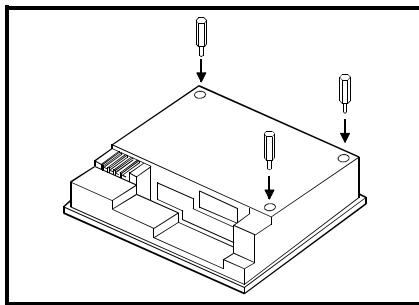

- 1) Fit the communication module securing fixtures in the GOT main unit.

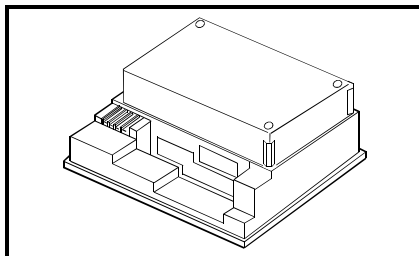

- 2) Mount the communication module on the GOT interface.

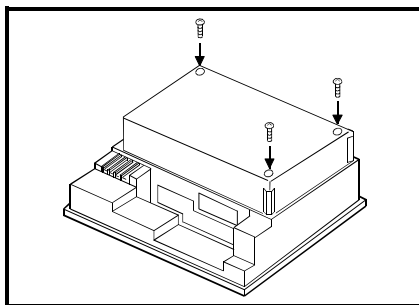

- 3) Tighten and fix the mounting screws (3 pcs.) of the communication module in the specified torque range.

## 6.8 Printer Interface Module

The printer interface module is connected to the GOT when the printer is used with the GOT.

The printer is used to print the data and others of the alarm history and hard copy functions.

For the details of the functions, refer to the [GT Designer Help Function].

### 6.8.1 Printer interface module type

The following printer interface module type is available.

| Type       | Description              |
|------------|--------------------------|
| A9GT-50PRF | Printer interface module |

### 6.8.2 How to connect the printer interface module

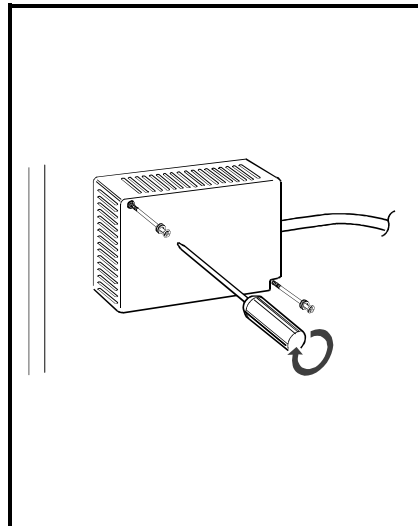

- 1) Thread A9GT-50PRF mounting screw holes in the control box or the like. (2- $\phi$  3.5 mounting holes)

The A9GT-50PRF's GOT connection cable is 50cm long.

Install the A9GT-50PRF within this distance so that the GOT-end connector of the cable may be fitted into the GOT's connector. When mounting the A9GT-50PRF on the back of control box door, exercise care to avoid screw holes passing through the control box surface.

- 2) Tighten the mounting screw to the specified torque range 39 to 59N • cm.

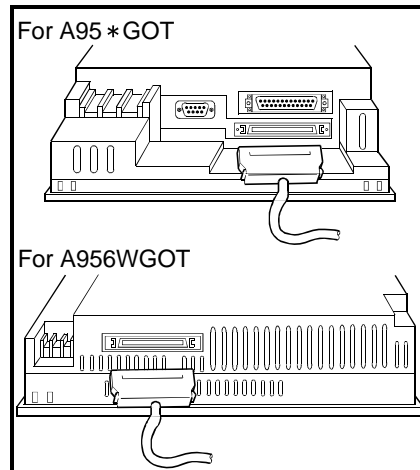

- 3) Plug the GOT side connector of the A9GT-50PRF to the option unit at the bottom of the GOT.

- When using the A9GT-50PRF, use the ROM\_BIOS of SW1D5C-GOTRE-PACK H version or later (ROM\_BIOS G version or later).
- For details of the printer interface module specifications, refer to the A9GT-50PRF type printer interface module User's Manual.

### 6.8.3 Printer types

The printer usable is any of the printers having the following specifications (standard) whose operations have been checked by Mitsubishi.

- ESC/P24-J84-compliant printer (ESC/P command-compatible, color-compatible)
- Hewlett Packard printers (PLC command compatible)

### 6.8.4 Connecting procedure

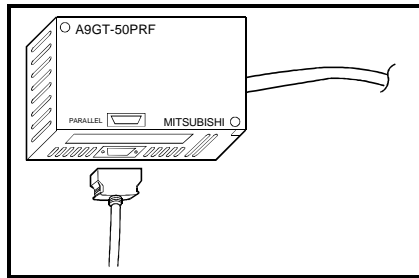

- 1) Plug the GOT side connector of the printer cable to the parallel interface of the A9GT-50PRF.
- 2) Connect the A9GT-50PRF and printer by the printer cable.

## 6.9 External I/O Module

The external I/O module is connected with the ten-key panel (A8GT-TK) or keyboard to receive up to 8/64 points of inputs or provide up to 16 points of outputs.

Refer to the GT Designer Help Function for details.

### 6.9.1 External I/O module type

The following external I/O module is available.

| Type       | Description         |
|------------|---------------------|
| A8GT-50KBF | External I/O module |

### 6.9.2 Mounting procedure

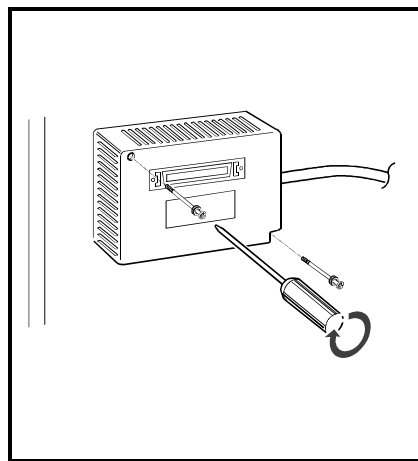

- 1) Thread A8GT-50KBF mounting screw holes in the control box or the like. (2- $\phi$  3.5 mounting holes)

The A8GT-50KBF's GOT connection cable is 50cm long.

Install the A8GT-50KBF within this distance so that the GOT-end connector of the cable may be fitted into the GOT's connector.

When mounting the A8GT-50KBF on the back of control box door, exercise care to avoid screw holes passing through the control box surface.

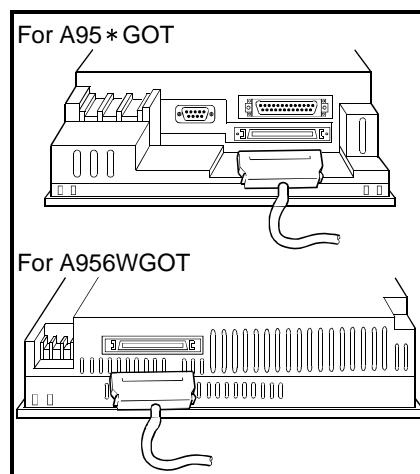

- 2) Tighten the mounting screws to the specified torque range 39 to 59N • cm.
- 3) Plug the GOT side connector of the A8GT-50KBF to the option unit of the GOT.

- When using the A8GT-50KBF, use the ROM\_BIOS of SW1D5C-GOTRE-PACK H version or later (ROM\_BIOS G version or later).
- For details of the External I/O module specifications, refer to the A8GT-50KBF type External I/O module User's Manual.

## 6.10 Bar Code Reader

The bar code reader is used for writing data that is read with the bar code reader into the programmable controller CPU. For details of the functions of the bar code reader, please refer to the [GOT-A900 Series User's Manual (GT Works Version5/GT Designer Version5 compatible Connection System Manual).]

### 6.10.1 Bar code reader types

The following are the applicable bar code readers whose operating performance has been checked and confirmed by Mitsubishi Electric Corporation:

- Names of manufacturer of bar code reader: Token, Opt-electronics, Keyence, Imex, OLYMPUS-symbol, Omron and Denso

### 6.10.2 Connecting procedure

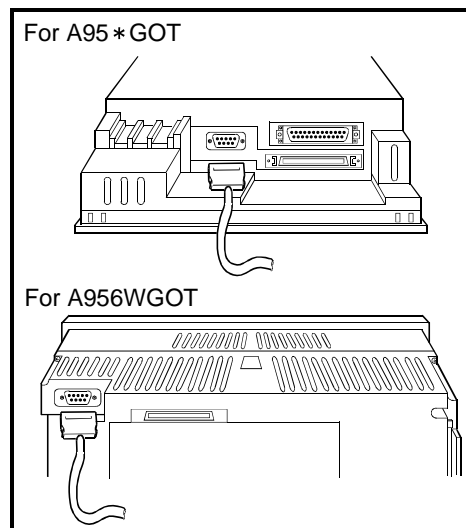

- 1) To the RS-232C interface of the GOT, choose and connect one from the following: the connector for the bar code reader; the connector for the power supply module; and the connector on the GOT for the RS-232C cable. (The connecting method differs depending on the kind of bar code reader that will be used.)

- Please note that the bar code reader cannot be used if the GOT is connected to the MELSECNET/B or MELSECNET II.
- The power supply (5V DC) needs to be supplied from an AC-DC adapter or a corresponding power module to the bar code reader.
- The RS-232C cable needs to be prepared by the user of this product. For details of preparations of the cable, please refer to the [GOT-A900 Series User's Manual (GT Works Version5/GT Designer Version5 compatible Connection System Manual).]

## 6.11 Debug Stand

The debug stand is used to secure the GOT in a standing position so that the monitor screen data may be debugged easily.

### 6.11.1 Debug stand type

The following debug stand type is available.

| Type          | Description              |
|---------------|--------------------------|
| A9GT-50STAND  | Debug stand for A95*GOT  |
| A9GT-50WSTAND | Debug stand for A956WGOT |

### 6.11.2 Mounting procedure

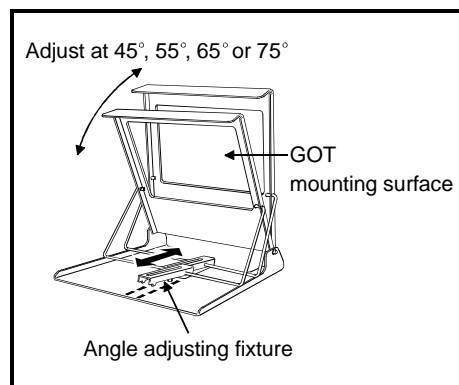

- 1) Adjust the GOT mounting angle with the angle adjusting fixture of the debug stand.
- 2) Put the GOT into the front face of the debug stand and mount it on the debug stand with the mounting fixtures of the GOT main unit.  
Refer to [Section 6.1.2] for the installation method using the mounting fixtures of the GOT main unit.

- For details of the debug stand specifications, refer to the A9GT-50STAND User's Manual or A9GT-50WSTAND User's Manual.

## 6.12 Attachment (A95\*GOT only)

The attachment is used to replace the A85\*GOT with the A95\*GOT.

By the use of the attachment, additional machining to the installation hole in the control panel of the A85\*GOT can be eliminated.

### 6.12.1 Attachment type

The following Attachment type is available.

| Type        | Model in use | Applicable model |
|-------------|--------------|------------------|
| A85GT-95ATT | A85*GOT      | A95*GOT          |

### 6.12.2 Mounting procedure

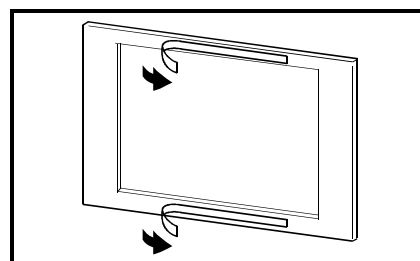

- 1) Peel off the pressure sensitive adhesive double coated tape from the rear surface of the attachment.

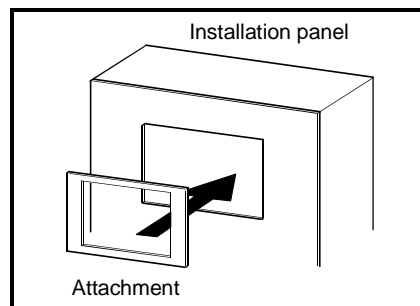

- 2) Install the attachment securely taking care so that it is positioned correctly in the installation panel mounting hole. If the installation panel is dirty, the attachment may fall, causing injury. Ensure to clean the installation panel by wiping it off before installation of the attachment.

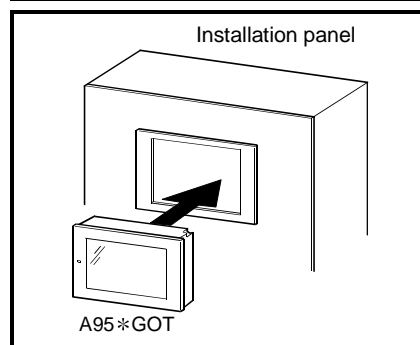

- 3) Insert the GOT main unit from the front of the attachment, and tighten it to the specified torque using the mounting screws furnished with the GOT main unit.

- The attachment can be used when the plate thickness of the installation panel is 1.2 (0.05) to 3 mm (0.12 in).  
When the plate thickness exceeds 3 mm (0.12 in), the attachment cannot be used for the replacement of the GOT.
- Once the GOT has been replaced with a new GOT by the use of the attachment, the new GOT does not meet the requirements specified in the standards for water and dust resistance IP65F/IP67F/NEMA4.



## 7 MAINTENANCE AND INSPECTION

This chapter explains the items which should be performed daily or periodically to use the GOT to its optimum.

### 7.1 Instructions for Maintenance and Inspection

The following instructions should be observed for maintenance and inspection.



#### DANGER

- When power is on, do not touch the terminals.  
Doing so can cause an electric shock or malfunction.
- Before starting cleaning or terminal screw retightening, always switch off the power externally in all phases.  
Not switching the power off in all phases can cause a module failure or malfunction.  
Undertightening can cause a short circuit or malfunction.  
Overtightening can cause a short circuit or malfunction due to the damage of the screws or module.
- Before changing the backlight, always turn the GOT power OFF (When using a GOT bus connection, also turn OFF the PLC CPU power), and remove the GOT main unit from the panel before changing the backlight.  
Not switching the power off in all phases may cause an electric shock.  
Not removing the unit from the enclosure can cause injury due to a drop.



#### CAUTION

- Do not disassemble or modify the module.  
Doing so can cause a failure, malfunction, injury or fire.
- Do not touch the conductive and electronic parts of the module directly.  
Doing so can cause a module malfunction or failure.
- The cables connected to the module must be run in ducts or clamped.  
Not doing so can cause the module or cable to be damaged due to the dangling, motion or accidental pulling of the cables or can cause a malfunction due to a cable connection fault
- When unplugging the cable connected to the module, do not hold and pull the cable portion.  
Doing so can cause the module or cable to be damaged or can cause a malfunction due to a cable connection fault.
- When disposing of the product, handle it as industrial waste.
- While changing the backlight, do not touch the circuit boards and electronic parts of the GOT.  
Doing so can cause a failure or malfunction.
- When replacing the backlight, use the gloves.  
Otherwise, it may cause you to be injured.  
If you should directly touch the plated area of the main unit case with hand, be sure to wipe off the fingerprint and so on, and install the main unit case.  
Otherwise, it may cause a trouble or malfunction.
- Start changing the backlight more than 5 minutes after switching the GOT power off.  
Not doing so can cause a burn due to the heat of the backlight.

7.2 Daily Inspection

Daily inspection items are as follows.

| Number | Inspection Item        |                                | Inspection Method                                      | Criterion        | Action                            |
|--------|------------------------|--------------------------------|--|------------------|-----------------------------------|
| 1      | Module mounting status |                                | Check for loose mounting screws and disconnected cover | Securely mounted | Retighten screws                  |
| 2      | Connection status      | Loose terminal screws          | Retighten screws with screwdriver                      | Not loose        | Retighten terminal screws         |
|        |                        | Proximate solderless terminals | Visual check   | Proper intervals | Correct                           |
|        |                        | Loose connectors               | Visual check   | Not loose        | Retighten connector fixing screws |

7.3 Periodic Inspection

Inspection items to be checked once or twice in six months or one year are as follows. The following inspection should also be performed when equipment has been moved or modified or the wiring changed.

| Number | Inspection Item            |                                | Inspection Method  | Criterion                        |           | Action  |
|--------|----------------------------|--------------------------------|--|----------------------------------|-----------|---|
| 1      | Surrounding environment    | Ambient temperature            | Make measurement with thermometer or hygrometer<br>Measure corrosive gas | Display section                  | 0 to 40°C | For use in enclosure, temperature inside enclosure is ambient temperature |
|        |                            | Ambient humidity               |  | Other portions                   | 0 to 55°C |   |
|        |                            | Atmosphere                     |  | 10 to 90%RH                      |           |   |
|        |                            |                                |  | No corrosive gas                 |           |   |
| 2      | Power supply voltage check |                                | 24VDC<br>Measure voltage across terminals                                | 20.4DC to 26.4V                  |           | Change supply power   |
| 3      | Mounting status            | Looseness                      | Move module  | Should be mounted firmly         |           | Retighten screws  |
|        |                            | Dirt, foreign matter           | Visual check   | No dirt, foreign matter sticking |           | Remove, clean   |
| 4      | Connection status          | Loose terminal screws          | Retighten screws with screwdriver  | Not loose                        |           | Retighten terminal screws   |
|        |                            | Proximate solderless terminals | Visual check   | Proper intervals                 |           | Correct   |
|        |                            | Loose connectors               | Visual check   | Not loose                        |           | Retighten connector fixing screws   |

## 7.4 How to Change the Backlight for Liquid Crystal

**POINT**

The backlight of the A95\*GOT-TBD, A956WGOT is not allowed to be replaced by users.

When the backlight must be replaced, contact your nearest dealer or branch office.

The GOT contains a backlight for the liquid crystal of the display device.

The luminance of the back light lowers as it is used.

Change the backlight if the screen of the display device has become difficult to look at due to the reduced luminance of the backlight.

Change the backlight in the following procedure.

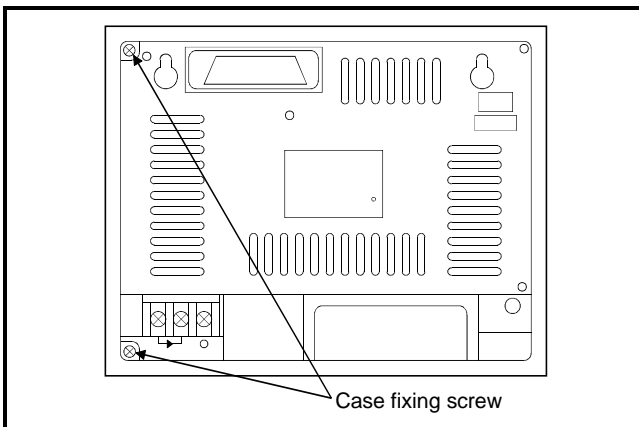

- 1) Turn the GOT's power off.  
Remove the wire from the power supply terminal and also remove the communications cable. When using the A956GOT, remove the network module.
- 2) After loosening the mounting fixtures of the GOT, remove the GOT from the enclosure.
- 3) Remove the fixing screws (2 pcs.) in the back of the GOT with a screwdriver.

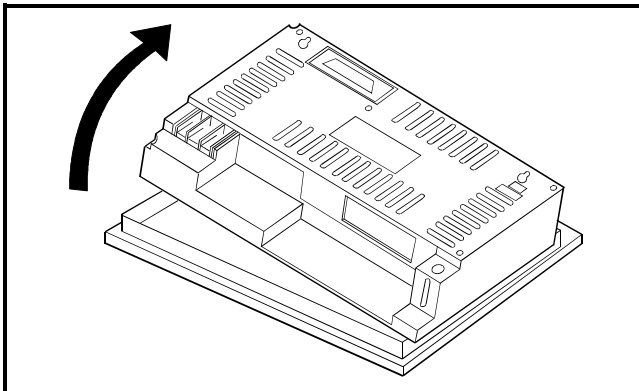

- 4) Remove the case on the back of the GOT.

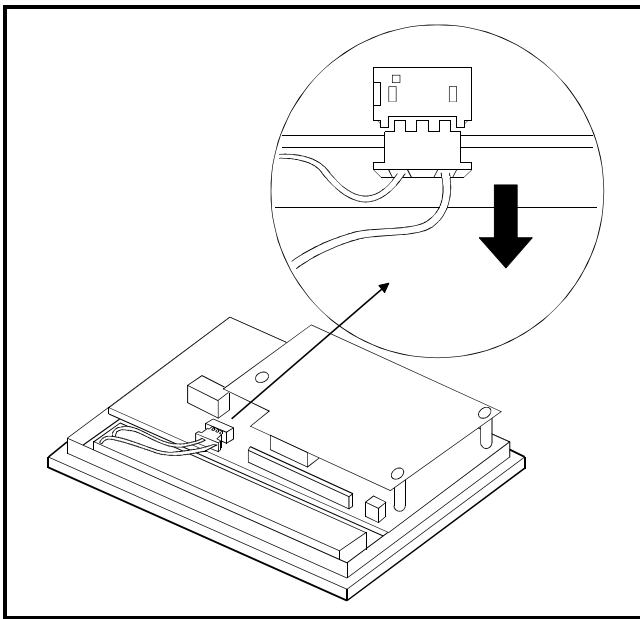

- 5) Unplug the cable connector of the backlight from the connector of the display device.

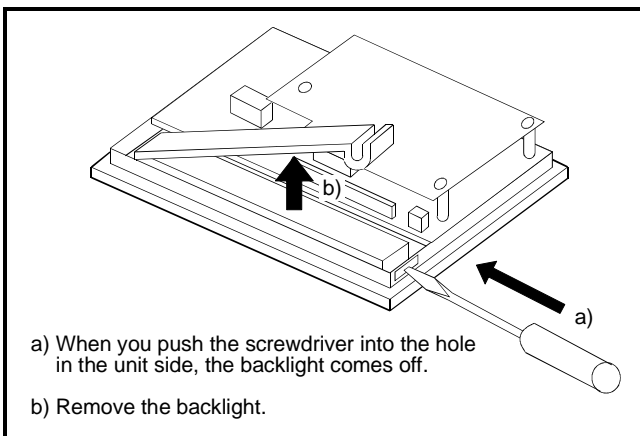

- 6) Remove the backlight from the display device. Using a flat-blade screwdriver makes removal easy.

- 7) Fit a new backlight in the reverse procedure of removal.  
To install the display unit, please follow the procedure reverse to that for removing. Please make sure to install the display unit securely and apply a torque within the torque range as specified to the fixing screws for the GOT.

\* When changing the backlight, use care not to touch the circuit board in the GOT.

### [Disposal Instructions]

#### ⚠ CAUTION

- To dispose of, please treat the back light as an industrial waste.

## 8 EMC Directive

For the products sold in European countries, the conformance to the EMC Directive, which is one of the European Directives, has been a legal obligation since 1996. Also, conformance to the Low Voltage Directive, another European Directives, has been a legal obligation since 1997.

Manufacturers who recognize their products must conform to the EMC and Low Voltage Directives required to declare that their products conform to these Directives and put a "CE mark" on their products.

|  |
|--|
| <b>POINT</b>   |
| Products that the EMC directive applies to are marked with the CE mark logo. |

### 8.1 Requirements for conformance to EMC Directive

The EMC Directive specifies that products placed on the market must "be so constructed that they do not cause excessive electromagnetic interference (emissions) and are not unduly affected by electromagnetic interference (immunity)".

The applicable products are requested to meet these requirements. The sections 8.1.1 through 8.3.3 summarize the precautions on conformance to the EMC Directive of the machinery constructed using the GOT.

The details of these precautions has been prepared based on the requirements and the applicable standards control. However, we will not assure that the overall machinery manufactured according to these details conforms to the above-mentioned directives. The method of conformance to the EMC directive and the judgment on whether or not the machinery conforms to the EMC Directive must be determined finally by the manufacturer of the machinery.

## 8.1.1 Standards applicable to the EMC Directive

| Specification    | Test item  | Test details  | Standard value  |
|------------------|--|---|---|
| EN50081-2 : 1995 | EN55011<br>Radiated noise *2                     | Electromagnetic emissions from the product are measured.                              | 30 M-230 MHz QP:<br>30 dB $\mu$ V/m (30 m in measurement range) *1<br>230 M-1000 MHz QP:<br>37 dB $\mu$ V/m (30 m in measurement range) |
|                  | EN55011<br>Conducted noise                       | Electromagnetic emissions from the product to the power line is measured.             | 150 k-500 kHz QP: 79 dB, Mean: 66 dB *1<br>500 k-30 MHz QP: 73 dB, Mean: 60 dB  |
| EN61131-2 : 1996 | EN61000-4-2<br>Electrostatic immunity *2         | Immunity test in which static electricity is applied to the cabinet of the equipment. | 8kV Aerial discharge  |
|                  | EN61000-4-4<br>Fast transient burst noise *2     | Immunity test in which burst noise is applied to the power line and signal lines.     | Power line: 2kV<br>Digital I/O (24V or higher): 1kV<br>(Digital I/O (24V or less)) > 250V<br>(Analog I/O, signal lines) > 250V          |
|                  | EN61000-4-3<br>Radiated field AM modulation *2   | Immunity test in which field is irradiated to the product.                            | 10V/m, 26-1000 MHz,<br>80%AM modulation @ 1 kHz   |
|                  | EN61000-4-12<br>Damped oscillatory wave immunity | Immunity test in which a damped oscillatory wave is superimposed on the power line.   | Power line: 1kV<br>Digital I/O (24V or higher): 1 kV  |

\*1 QP : Quasi-peak value, Mean : Average value

\*2 The GOT is an open type device (device installed to another device) and must be installed in a conductive control panel or cabinet.

About these test items, install the control panel, combine with a PLC from this company, and run a test.

### 8.1.2 Control cabinet

The GOT is an open type device (device installed to another device) and must be installed in a conductive control panel or cabinet.

It not only assure the safety but also has a large effect to shut down the noise generated from GOT, on the control panel.

#### (1) Control cabinet

(a) Use a conductive control cabinet.

(b) When attaching the control cabinet's top plate or base plate, mask painting and weld so that good surface contact can be made between the cabinet and plate.

(c) To ensure good electrical contact with the control cabinet, mask the paint on the installation bolts of the inner plate in the control cabinet so that contact between surfaces can be ensured over the widest possible area.

(d) Earth the control cabinet with a thick wire so that a low impedance connection to ground can be ensured even at high frequencies. (22mm<sup>2</sup> wire or thicker is recommended.)

(e) Holes made in the control cabinet must be 10 cm (3.94in.) diameter or less. If the holes are 10cm (3.94in.) or larger, radio frequency noise may be emitted. In addition, because radio waves leak through a clearance between the control panel door and the main unit, reduce the clearance as much as practicable.

The leakage of radio waves can be suppressed by the direct application of an EMI gasket on the paint surface.

Our tests have been carried out on a panel having the damping characteristics of 37 dB max. and 30 dB mean (measured by 3 m method with 30 to 300 MHz).

#### (2) Connection of power and ground wires

Ground and power supply wires for the GOT must be connected as described below.

(a) Provide an earthing point near the GOT. Earth the power supply's FG terminal (FG: Frame Ground) with the thickest and shortest wire possible. (The wire length must be 30cm (11.18in.) or shorter.)

The FG terminal function is to pass the noise generated in the GOT to the ground, so an impedance that is as low as possible must be ensured.

As the wires are used to relieve the noise, the wire itself carries a large noise content and thus short wiring means that the wire is prevented from acting as an antenna.

Note) A long conductor will become a more efficient antenna at high frequency.

### (3) Electrical shock prevention

In order to such as the operators from electric shocks, the control box must have the following functions :

(a) The control cabinet must be equipped with a lock so that only skilled or qualified personnel.

(b) The control cabinet must be fitted with advice which automatically stops the power supply when the cabinet is opened.

### (4) Dustproof and waterproof features

The control box also has the dustproof and waterproof functions. Insufficient dustproof and waterproof features lower the insulation withstand voltage, resulting in insulation destruction. The insulation in our GOT is designed to cope with the pollution level 2, so use in an environment with pollution level 2 or better.

Pollution level 1: An environment where the air is dry and conductive dust does not exist.

Pollution level 2: An environment where conductive dust does not usually exist, but occasional temporary conductivity occurs due to the accumulated dust.

Generally, this is the level for inside the control box equivalent a control room or on the floor of a typical factory.

Pollution level 3: An environment where conductive dust exists and conductivity may be generated due to the accumulated dust.

An environment for a typical factory floor.

Pollution level 4 : Continuous conductivity may occur due to rain, snow, etc.  
An outdoor environment.

## 8.1.3 Grounding

It is necessary to use the GOT grounding terminal only when it is in the grounded condition.

Be sure to ground the grounding for the safety reasons and EMC Directives.

Functional grounding  : Improves the noise resistance.



### 8.2 System Configuration when EMC Directive is Applicable

Connection conditions and models where the EMC directive is applicable are shown below.

#### 8.2.1 Overall Configuration

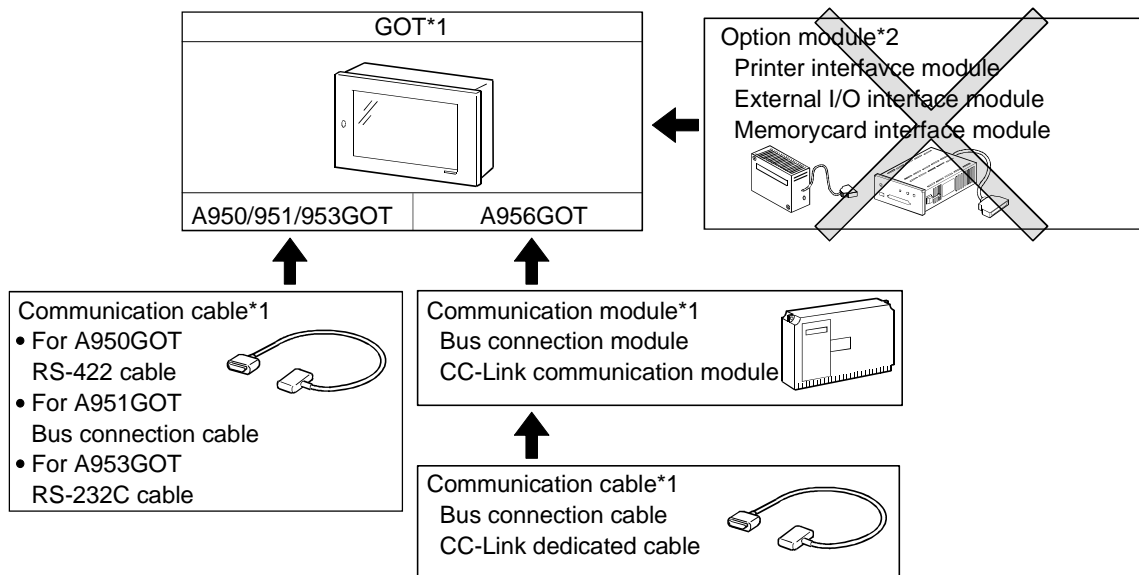

\*1 See section 8.2.3 for information about models and hardware versions that are applicable to the EMC directive.

\*2 EMC directive is not applicable when using an option module.

#### 8.2.2 Connection Format

Connection conditions where the A95\*GOT is applicable to the EMC directive are shown below.

○ : EMC directive applicable × : EMC directive not applicable — : Connection impossible

| Item      | Bus connection | CPU Direct connection |                   | MELSEC NET connection | Computer link connection |        | CC-link connection | Ethernet connection |
|-----------|----------------|-----------------------|-------------------|-----------------------|--------------------------|--------|--------------------|---------------------|
|           |                | RS-232C (QCPU)        | RS-422 (A/QNACPU) |                       | RS-232C                  | RS-422 |                    |                     |
| A950GOT   | —              | —                     | ○                 | —                     | —                        | ○      | —                  | —                   |
| A951GOT-Q | ×              | —                     | —                 | —                     | —                        | —      | —                  | —                   |
| A951GOT   | ○              | —                     | —                 | —                     | —                        | —      | —                  | —                   |
| A953GOT   | —              | ○                     | —                 | —                     | ○                        | —      | —                  | —                   |
| A956GOT   | ○              | —                     | —                 | ×                     | —                        | —      | ○                  | ×                   |

**POINT**  
 If connecting to a PLC not from this company (MELSEC-Q series, MELSEC-QnA series, MELSEC-A series), refer to the manual of the connected device (PLC, microcomputer) for information about the applicability of the EMC directive.

8.2.3 About Models Applicable to the EMC Directive

Models and applicable hardware versions that are applicable to the EMC directive are shown below. (Available May, 2001)

Be sure to use a hardware product version shown below or later version to make the product applicable to the EMC directive.

(1) For A950GOT/A951GOT/A953GOT

| Item  | Type             | Hardware version         |                              |
|---|------------------|--------------------------|------------------------------|
|   |                  | EMC directive applicable | EMC directive not applicable |
| A950GOT*1<br>(Built-in RS-422 communication interface)                        | A950GOT-SBD(-M3) | Version L or later       | Version K or earlier         |
|   | A950GOT-LBD(-M3) |                          |                              |
| A951GOT<br>(Built-in QnA/A/Motion controller CPU Bus communication interface) | A951GOT-SBD(-M3) |                          |                              |
|   | A951GOT-LBD(-M3) |                          |                              |
| A953GOT<br>(Built-in RS-232C communication interface)                         | A953GOT-SBD(-M3) |                          |                              |
|   | A953GOT-LBD(-M3) |                          |                              |

\*1 Be aware that if using A950GOT after removing the control panel as described in item 6.1.4, it is not applicable to the EMC directive.

(2) For A956GOT

Be sure to use the communication modules shown below with A956GOT. If communication modules other than those shown below are used, they are not applicable to the EMC directive.

| Item   | Type             | Hardware version         |                              |
|--|------------------|--------------------------|------------------------------|
|  |                  | EMC directive applicable | EMC directive not applicable |
| A956GOT(Built-in communication module interface) | A956GOT-SBD(-M3) | Version K or later       | Version J or earlier         |
|  | A956GOT-LBD(-M3) |                          |                              |
| Bus Connection module                            | A9GT-BUSSU       | Version B or later       | Version A or earlier         |
|  | A9GT-BUS2SU      |                          |                              |
| CC-Link communication module                     | A8GT-J61BT13     | Version E or later       | Version D or earlier         |
|  | A8GT-J61BT15     | Version C or later       | Version B or earlier         |

**POINT**

Confirm the hardware version with the products rating plate.  
(Products that the EMC directive applies to are marked with the CE mark logo.)

CE mark logo

Hardware version

## 8.2.4 About the Cable Used

If making the GOT applicable to the EMC directive, be sure to use the cables shown below.

○: EMC directive applicable ×: EMC directive not applicable

| Connection format        |                       | Cable  | EMC Directive |
|--------------------------|-----------------------|--|---------------|
| Bus connection           | A/QnACPU              | AC06/12/30/50B,<br>AC12/30/50B-R,<br>A1SC07/12/30/50B,<br>A1SC05/07/30/50NB,<br>A8GT-C12/30/50NB,<br>A370C12/25B,<br>A9GT-J2C10B,<br>A8GT-C100/200/300EXSS,<br>A8GT-C100/200/300BS | ○             |
|                          | QCPU (Q mode)         | QC06/12/30/50/100B, A9GT-QC150/200/250/300/350BS   | ×             |
| CPU direct connection    | RS-232C communication | QC30R2   | ○             |
|                          | RS-422 communication  | AC30/100/300R4-25P   | ○             |
| Computer link connection | RS-232C communication | User created cable   | ○             |
|                          | RS-422 communication  | AC30/100/300R4-25P, User created cable   | ○             |
| CC-Link communication    |                       | CC-Link dedicated cable  | ○             |

**POINT**

To make applicable to the EMC directive, each cable (including user created cables) must be manufactured.

Refer to section 8.3.2. for the cable manufacturing method.

### 8.3 Wiring precautions the part which matches the EMC Directives

Connect and wire GOT equipment as instructed below.

If the GOT equipment is configured in a way that differs from the following instructions then the system will not comply with EMC directives.

#### 8.3.1 Method to connect the power wire and ground wire

- (1) With the power wire, be sure to attach the ferrite core (TDK type ZCAT3035-1330) within 90 mm of the GOT terminal module.

Lead the power wire and ground wire as shown in Section 8.1.2 (2).

Always ground the FG wires.

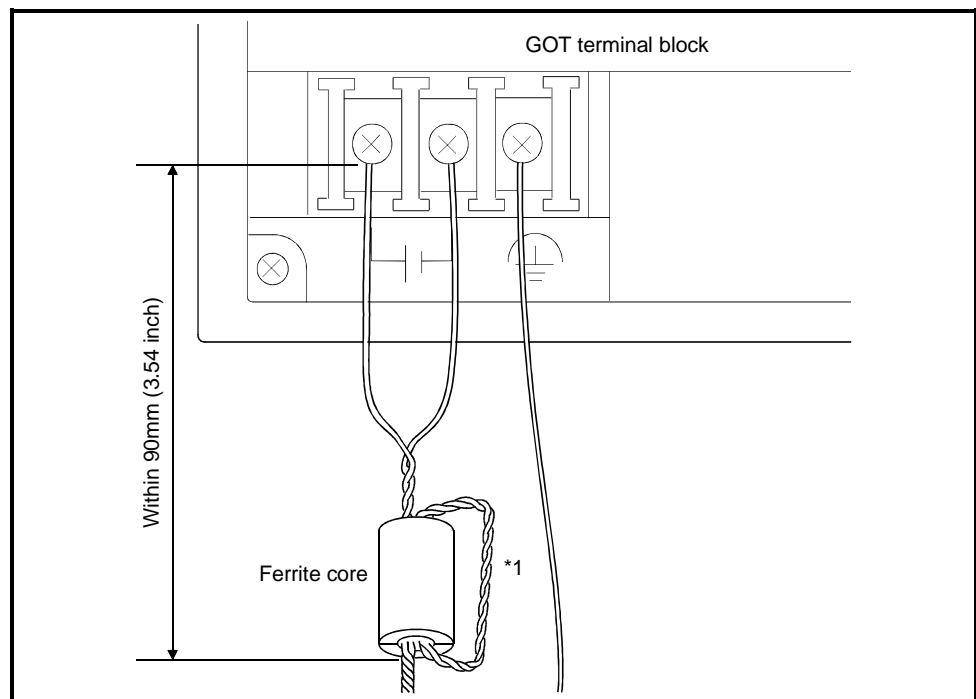

\*1 Wrap the power wire around the ferrite core.

- (a) When connecting CC-Link, use the grounding wire of the FG1 terminal on the CC-Link communication module to connect to the FG terminal of the GOT power section.

Use a grounding wire of 300 mm or less.

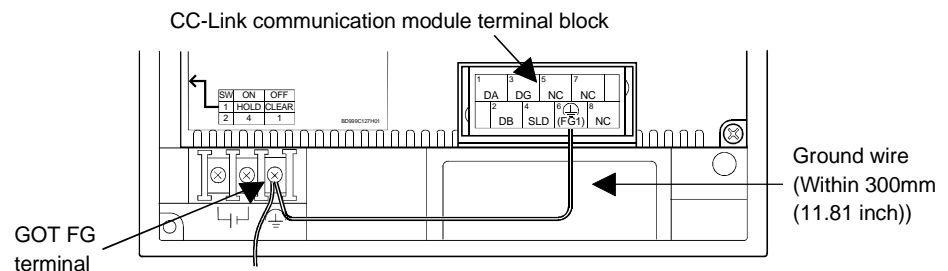

#### POINT

Use a CE compatible product for 24 V DC external common power source for GOT. The EMC test run by our company was confirmed with the same panel components as the Nemic-Lambda type JWS 50-24 installed.

### 8.3.2 Grounding the ground cable

Manufacture the cable used with the GOT with the following method.

When manufacturing the cable, a ferrite core, cable clamp and cable shielding material are required.

The cable clamp used by Mitsubishi Electric for the EMC specification compatibility test is shown below.

- TDK brand ZCAT3035-1330 Ferrite Core
- Mitsubishi Electric Model AD75CK cable clamp
- Japan Zipper Tubing Co., Ltd. Zipper tube SHNJ type

#### (1) Bus Connection

##### (a) For A8GT-C100/200/300EXSS, A8GT-C100/200/300BS

- Cut the ground wire from the core where it protrudes from both ends of the cable.

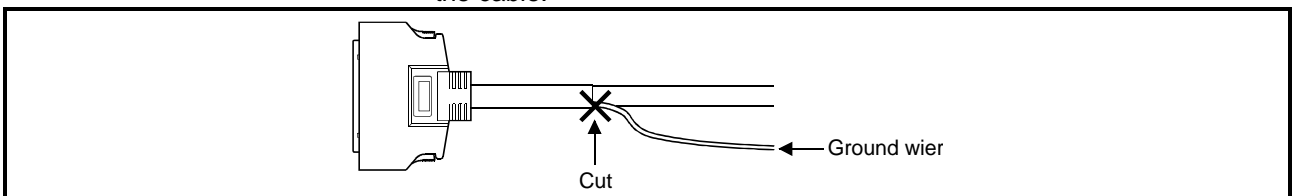

- Peel the sheath (with the length shown below) at both ends of the cable, and expose the shield braided wire for grounding.

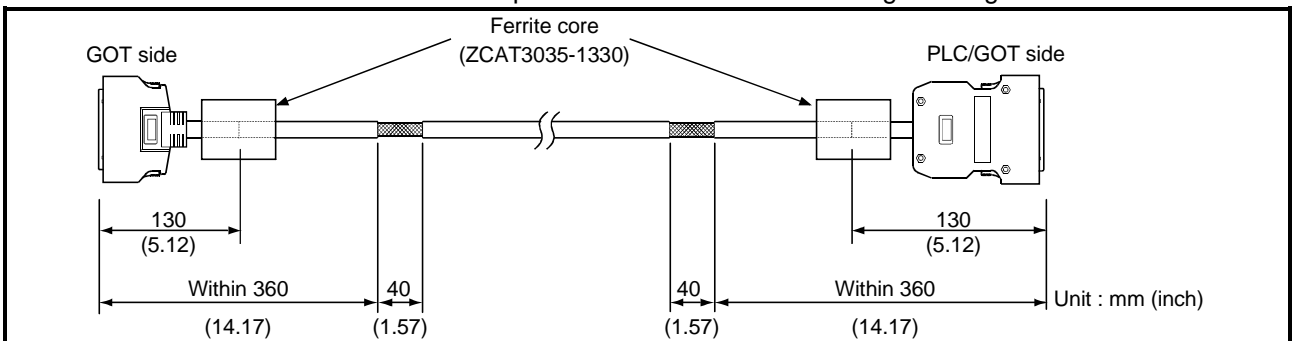

##### (b) For other Bus Connection cables

- Wrap the cable shield material around the cable, so that the back aluminum foil side (shield side) of the cable shield material is exposed at both ends of the cable.

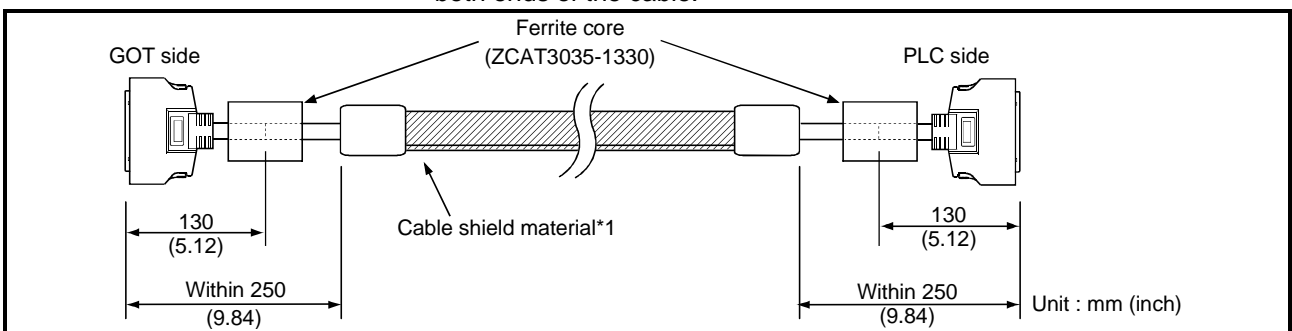

\*1 The back aluminum foil side of the cable shield material (shield side) should be exposed.

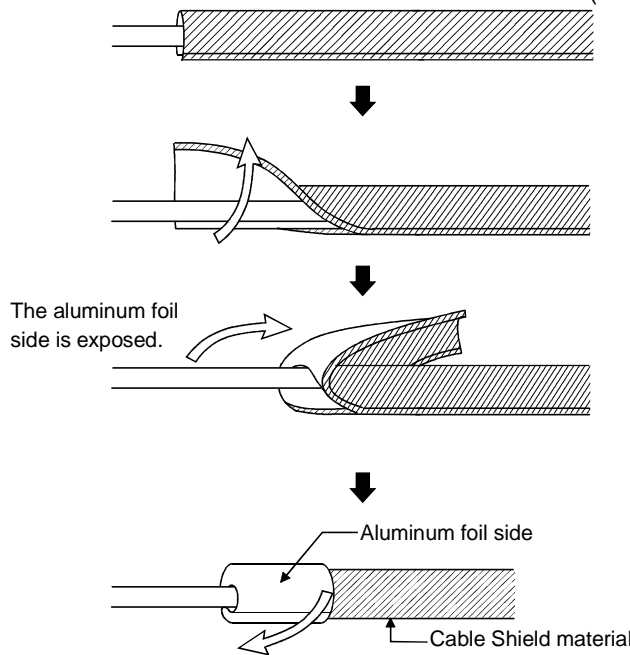

(2) CPU Direct Connection

(a) For RS-232C cable (QC30R2)

- Peel the sheath (with the length shown below) at both ends of the cable, and expose the shield braided wire for grounding.

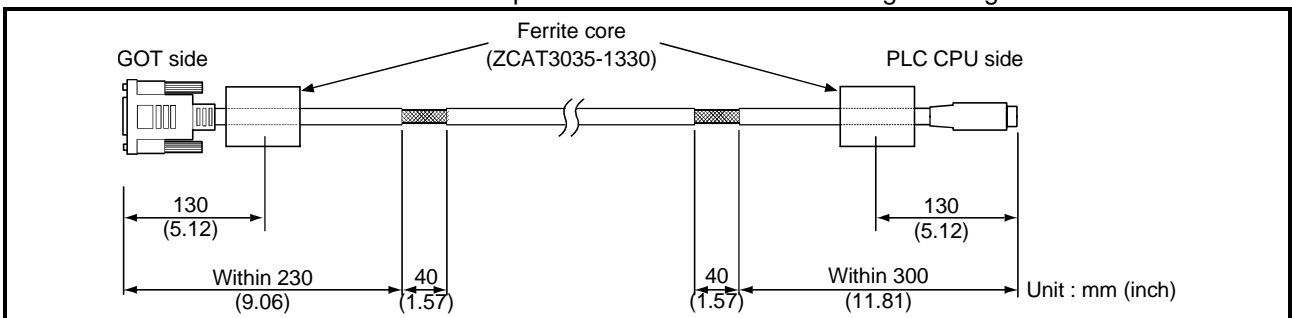

(b) For RS-422 cable (AC30/100/300R4-25P)

- Peel the sheath (with the length shown below) at both ends of the cable, and expose the shield braided wire for grounding.

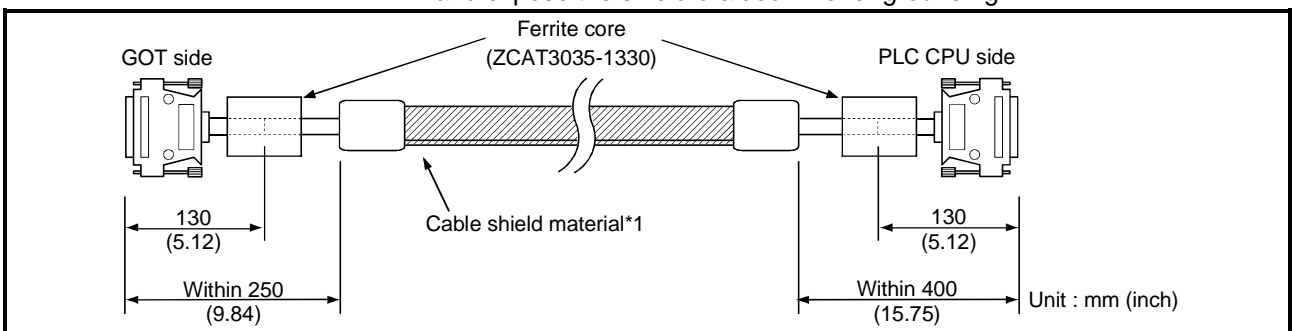

\*1 The back aluminum foil side of the cable shield material (shield side) should be exposed. (Refer to section 8.3.2 (1) (b))

(3) Computer Link Connection

(a) For RS-232C cable

The user needs to fabricate the RS-232C cable which is used to connect the GOT and Computer link unit side (serial communication, computer link module or PLC CPU with computer link function).

The RS-232C cable connection diagram and the connector are as follows.

1) Connection diagram

- If D-sub 9-pin is used for the connector of the computer link unit.  
(A1SJ71QC24(-R2), A1SJ71UC24-R2, A1SJ71C24-R2, A1SCPUC24-R2, A2CCPUC24, QJ71C24(-R2))

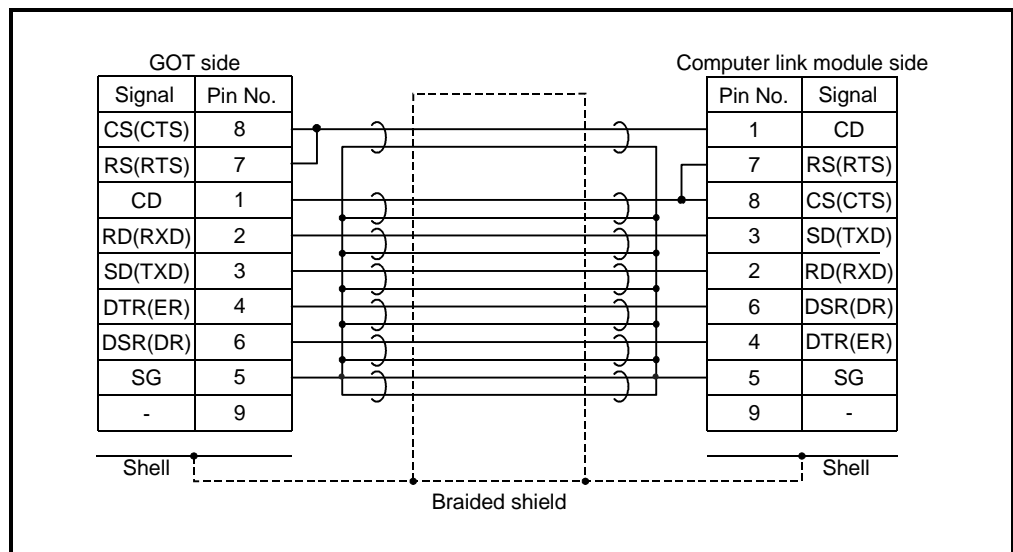

- If D-sub 25-pin is used for the connector of the computer link unit.  
(AJ71QC24(-R2), AJ71UC24)

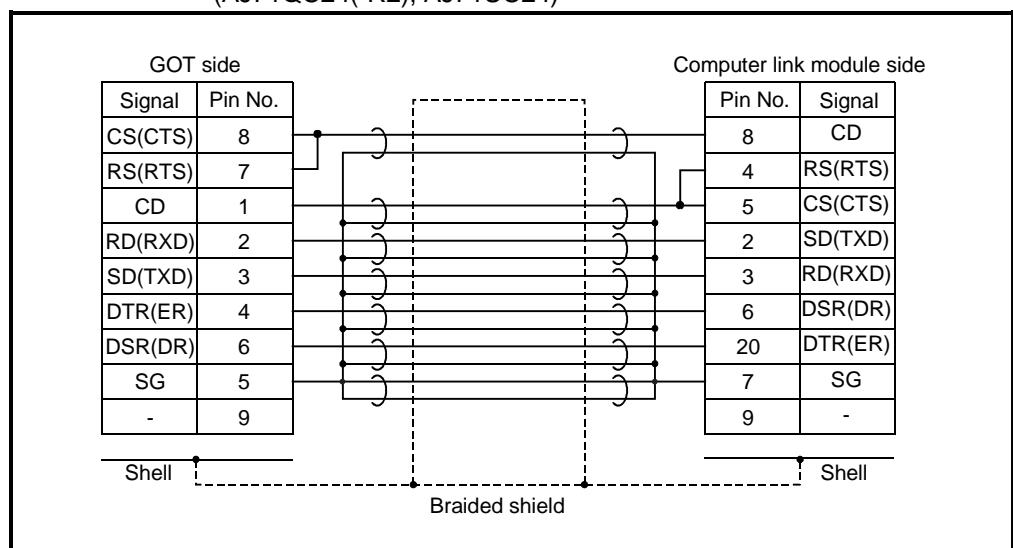

2) Precautions for manufacturing cable

- Make a twisted pair for each signal and SG.
- Connect the braided shield to the connector shell (both ends).
- The cable used for the Mitsubishi EMC Directive compatibility test had the following specifications.

| Item                                      | Specification             |
|---|---------------------------|
| Cable type                                | Twisted pair shield cable |
| Conductor section area (mm <sup>2</sup> ) | 0.2                       |

3) Connector (connector cover)

- GOT connector  
Use the connector matching the following model for the GOT.  
9-pin D-sub (male) inch screw type  
manufactured by DDK  
17JE-23090-27 (D3CC)
- Connector of computer link unit  
Refer to the user's manual of the serial communication, computer link module or PLC CPU with computer link function.

4) Cable production method

- Peel the sheath (with the length shown below) at both ends of the cable, and expose the shield braided wire for grounding.
- The cable must be 15m or shorter.

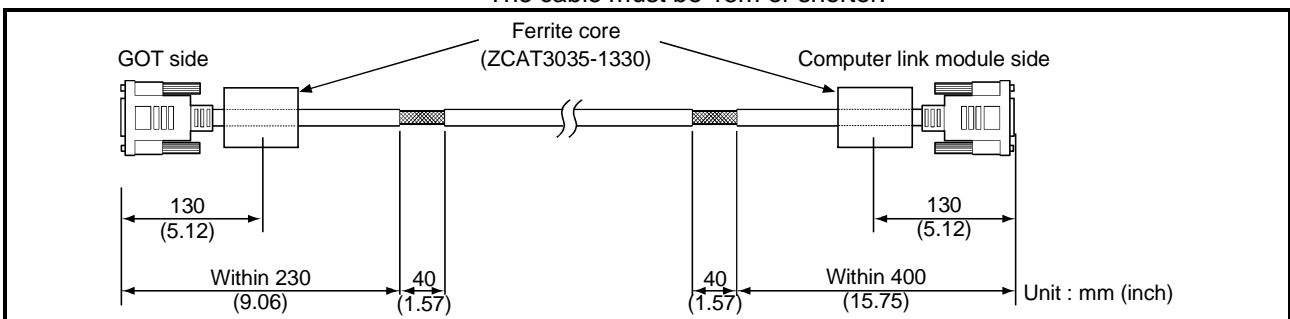



- (b) For RS-422 cable (AC30/100/300R4-25P, User created cable)  
Refer to the GOT-A900 series User's Manual (GT Works Version 5/GT Designer Version 5 compatible Connection System Manual) for information about the cable creation method.

- Wrap the cable shield material around the cable, so that the back aluminum foil side (shield side) of the cable shield material is exposed at both ends of the cable.

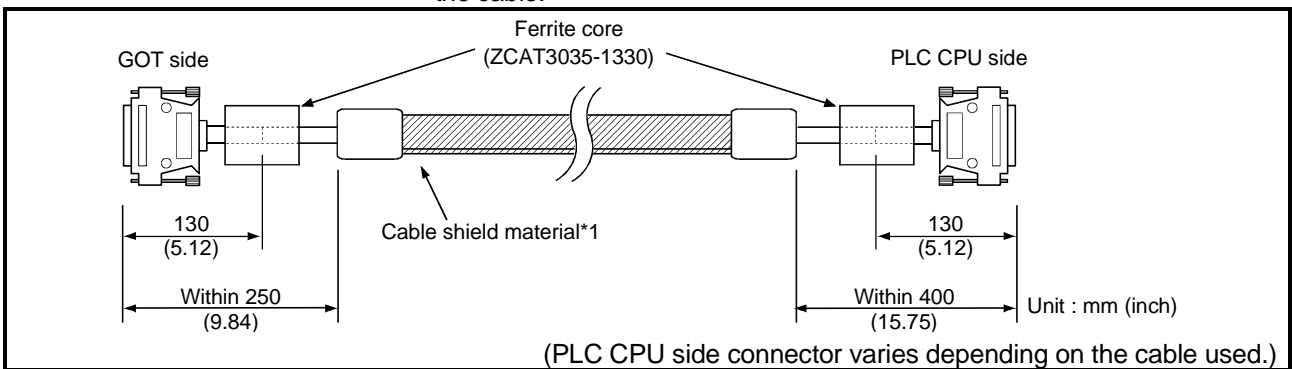

\*1 The back aluminum foil side of the cable shield material (shield side) should be exposed. (Refer to section 8.3.2 (1) (b))

(4) CC-Link Connection

- (a) For CC-Link dedicated cable

- Peel the sheath (with the length shown below) at both ends of the cable, and expose the shield braided wire for grounding.

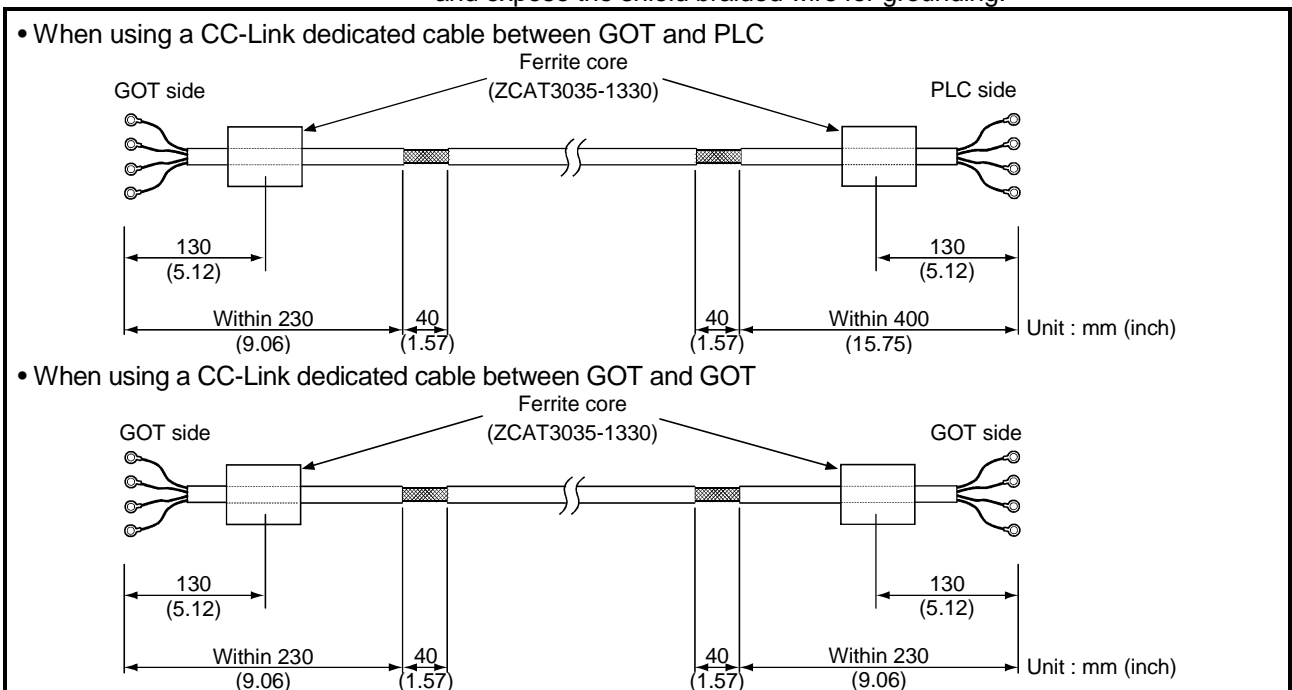

(5) Other PLC and Microcomputer connection

It is necessary for the user to create the cable used to connect GOT with a PLC or a microcomputer from another company (RS-422 cable or RS-232C cable). Refer to the GOT-A900 series User's Manual (GT Works Version 5/GT Designer Version 5 compatible Connection System Manual) for information about the cable creation method.

**POINT**

When connecting GOT to a PLC or microcomputer from another company, configure the system so that the EMC directive specifications from the connection destination are applicable.

The contents shown below are a collection of the contents that should be enforced when made applicable to the EMC directive; however, the final decision to make the device applicable to the EMC directive and how to make it applicable must be made by the manufacturer of the machine device.

(a) For RS-422 cable

- Each signal wire (excluding SG and FG) should be made into a two power wires and connected, then twisted.

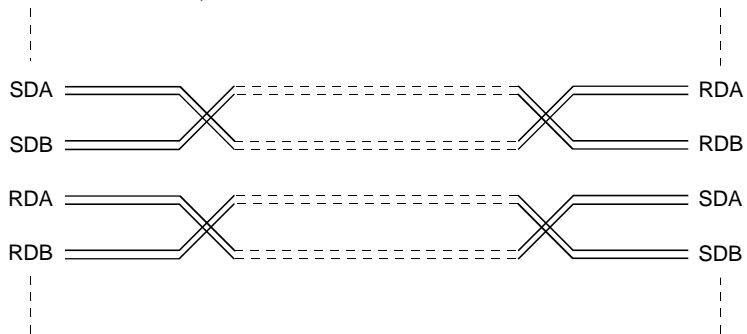

- Make the SG wire more than two wires and connect.
- Wrap the cable shield material around the cable, so that the back aluminum foil side (shield side) of the cable shield material is exposed at both ends of the cable.

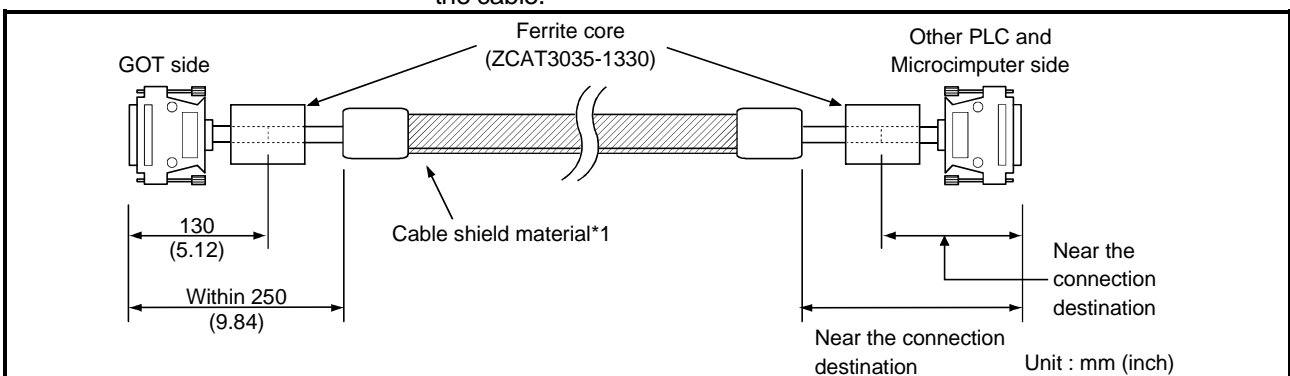

\*1 The back aluminum foil side of the cable shield material (shield side) should be exposed. (Refer to section 8.3.2 (1) (b))

(b) For RS-232C cable

- Each signal wire (excluding SG, FG) is twisted with SG.

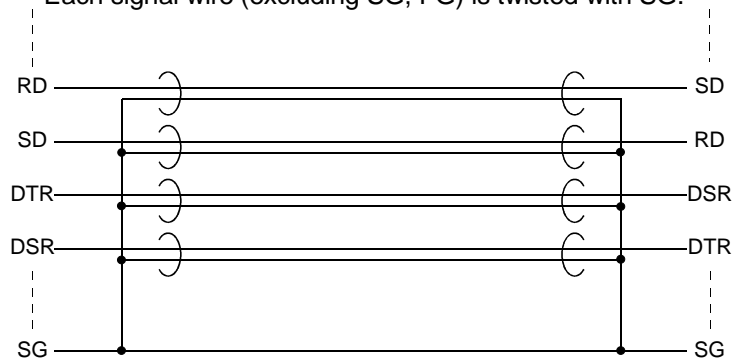

- Peel the sheath (with the length shown below) at both ends of the cable, and expose the shield braided wire for grounding.

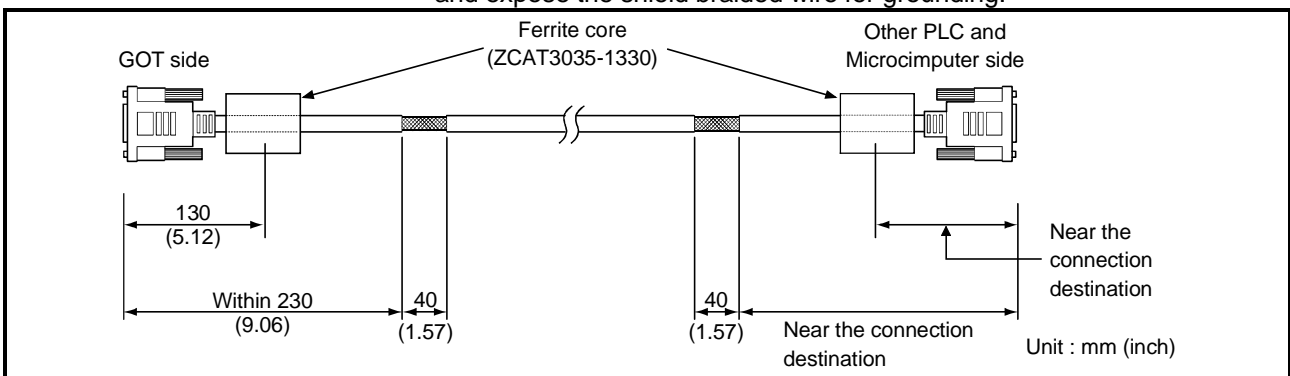

8.3.3 Grounding the cable

Ground the cable grounding sections and grounding wire to the control panel where the GOT and base unit are grounded.

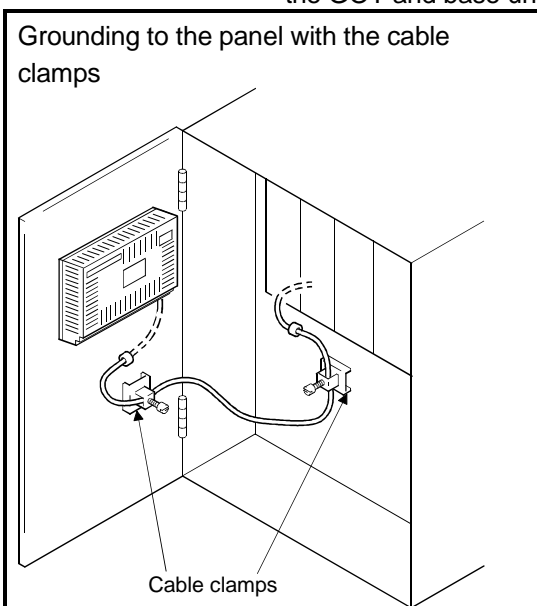

- Bus connection cable (For A8GT-C100/ C200/300EXSS, A8GT-C100/200/300BS), RS-232C cable, and CC-Link dedicated cable ground the shield braided wire and grounding wire to the panel with a cable clamp (AD75CK).
- For another bus cable or RS-422 cable, ground the shield side of the cable shield material to the panel with a cable clamp (AD75CK).

## 9 ERROR CODES AND ERROR MESSAGES

This chapter explains the error codes and error messages displayed by the alarm list (system alarm) display function of the monitoring functions.

The error codes may also be confirmed in the error code storage area of the system information function.

For more information on the alarm list (system alarm) display function and system information function, refer to [GT Designer Help Function].

### 9.1 Definition of the Error Codes and Messages Displayed

This section describes the definition of the error codes and error messages displayed on the monitor screen by the alarm list (system alarm) display function and the manuals to refer to.

- (1) Display format on the monitor screen ----- Displayed in the user-set position

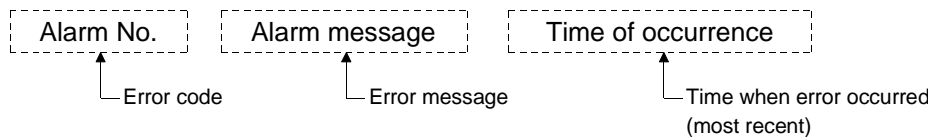

- (2) Error codes and manuals to refer to

| Source of Error Occurrence | Error Code                     | Where to Refer To  |
|----------------------------|--------------------------------|--|
| ACPU                       | 0 to 199<br>(Value of D9008)   | [User's Manual of ACPUs where GOT is connected]            |
| MNET/B, MNET(II)           | 200 to 299                     | [Data Link System Reference Manual of MNET(II), MNET/B] *1 |
| GOT                        | 300 to 499                     | [Section 9.2]  |
| MNET/10                    | 500 to 799                     | [Network System Reference Manual of MNET/10] *2            |
| CC-Link                    | 800 to 999                     | [CC-Link System Master ● Local Module User's Manual] *3    |
| QnACPU                     | 1000 to 9999<br>(Value of SD0) | [User's Manual of QnACPU where GOT is connected]           |

\*1 Take action with reference to the section explaining the link special relay of the (error code) + 9000.

For example, when the error of error code (210) has occurred, 210 + 9000 = 9210 and refer to the explanation of M9210 and take the corrective action.

\*2 Take action with reference to the section explaining the link special relay of the (error code) – 500.

For example, when the error of error code (510) has occurred, 510 - 500 = 10 and refer to the explanation of SB000A and take the corrective action.

(Since the link special relay is in hexadecimal, replace a decimal by a hexadecimal.)

\*3 Take action with reference to the section explaining the link special relay of the (error code) - 800.

For example, when the error of error code (910) has occurred, 910 – 800 = 110 and refer to the explanation of SB006E and take the corrective action.

(Since the link special relay is in hexadecimal, replace a decimal by a hexadecimal.)

\*4 The FXCPU has error codes 100 to 109 and displays the states of M8060 to M8069 with the error codes.

For example, when the error of error code (100) has occurred, refer to the explanation of M8060 and take the corrective action.

9.2 Error Code and Error Message List

(1) Error messages displayed before execution of monitoring

| Error Message  | Definition   | Action   |
|--|--|--|
| Check communication line.<br>(Cable, driver, module) | The cable, installed communication driver or communication module is faulty. | 1. Check for any disconnected cable or improperly fitted communication module.<br>2. check the installed communication driver. |
| Check memory data.                                   | Unauthorized combination of OS program versions installed.                   | Confirm the versions of the OS programs installed.   |

(2) Error codes and messages displayed during execution of monitoring

The error codes and messages detected by the GOT are indicated below.

| Error Code | Error Message                                      | Definition   | Action   |
|------------|--|--|--|
| 303        | Too many monitor points specified                  | The number of objects set to the screen to be displayed is too many to reserve the work area of the system   | Reduce the number of objects   |
| 304        | Too many trigger points specified                  |  |  |
| 305        | Too many print-out points specified                |  |  |
| 306        | No monitor data                                    | Screen data has not been downloaded to the built-in memory   | Download the screen data to the built-in memory  |
| 307        | No monitor device setting                          | Object monitoring devices not determined   | Determine object monitoring devices  |
| 308        | Specified comment not found or outside range       | The comment number set for comment display does not exist or the comment file does not exist   | Create the comment file and download it to the GOT   |
| 309        | Device read error                                  | Device data read caused an error   | Correct device   |
| 310        | Specified monitor data not found or outside range  | (1) The specified base screen/window screen does not exist in the project data.<br>(2) The specified base screen/window screen is outside the permissible range. | (1) Specify the existing base screen/window screen.<br>(2) Specify the existing base screen/window screen.                             |
| 311        | More than 1024 alarms in alarm history             | The alarms in the history has exceeded the largest number of points (1024 points) which the alarm history display function can monitor                           | Reduce the alarms in the alarm history<br>(Remove the history recovered)   |
| 315        | Device write error                                 | Data write to device caused an error   | Correct device   |
| 316        | Operation result value cannot be displayed/entered | The data operation result has exceeded the range which can be represented by the device type   | Reconsider the data operation formula so that the operation result does exceeded the range which can be represented by the device type |
| 320        | Specified part not found or outside range          | The part number set for part display does not exist.   | Confirm the part number specified for the part display in the screen data  |

| Error Code | Error Message  | Definition   | Action   |
|------------|--|--|--|
| 321        | Unauthorized station number specified for monitor device | The station number specified as a monitor destination does not exist or is not the station to be monitored | Confirm the monitor destination station number in the screen data  |
| 322        | Specified device outside range                           | The device number to be monitored is outside the permissible range of the corresponding PLC CPU            | Set the monitored PLC CPU and parameters to set the device in the monitorable range                                |
| 323        | Specified file register outside range                    |  |  |
| 324        | AD51H-dedicated device used without AD51H                | The AD51H-dedicated device was monitored in the system which does not use the AD51H                        | Incorporate the AD51H into the system or stop monitoring of the AD51H-dedicated device                             |
| 325        | Specified special module not loaded                      | The specified special module is not loaded   | Check the loading status of the specified special module   |
| 330        | PC card capacity short                                   | The PC card does not have enough capacity  | Check the capacity   |
| 331        | PC card not loaded or memory card access switch OFF      | The PC card is not loaded or the memory card access switch is OFF  | 1. Load the PC card<br>2. Turn ON the access switch  |
| 332        | Format error   | The PC card is not formatted   | Format the PC card   |
| 333        | PC card write-protected to disable write                 | The PC card is write-protected   | Make the PC card write-enabled   |
| 334        | PC card fault  | PC card failure  | Change the PC card   |
| 335        | PC card battery voltage low                              | The battery voltage of the PC card is low  | Change the battery of the PC card  |
| 340        | Printer in error or power off                            | The printer is faulty or its power is not on   | 1. Check the printer   |
| 341        | Printer fault  |  | 2. The Printer switch it on  |
| 345        | BCD/BIN conversion error                                 | It has been attempted to display/enter a value that cannot be BCD/BIN converted                            | 1. Change the device data to be displayed into a BCD value<br>2. Enter the value of 4-digit integer                |
| 350        | RS-232C communication error                              | The cable used to connect the GOT and personal computer is faulty  | 1. Check for an unplugged communication cable connector<br>2. check the cables used                                |
| 351        | Recipe file abnormal                                     | Recipe file data are not normal  | 1. Check recipe file data in PC card<br>2. Start GOT after deleting recipe file in PC card                         |
| 352        | Recipe file generation error                             | Recipe file generation failed  | Start GOT after loading PC card  |
| 353        | Recipe file write disabled                               | Data write to recipe file failed   | 1. Check write protect of PC card<br>2. Check PC card capacity<br>3. Do not unload PC card during recipe operation |
| 354        | Error during recipe file write                           | Error occurred during recipe file write  | Do not unload PC card during recipe operation  |
| 355        | Error during recipe file read                            | Error occurred during recipe file read   | 1. Do not unload PC card during recipe operation<br>2. Check recipe file data (device values) in PC card           |

| Error Code | Error Message   | Definition   | Action   |
|------------|---|--|--|
| 356        | File system error occurred in the PLC                                   | When the file register name is designated and then the recipe function is operated, an error occurs in the designated file register.                 | <ol style="list-style-type: none"> <li>1. Check the file register name, and then operate the recipe function again.</li> <li>2. Apply Format PLC memory to the designated PLC drive with the GX Developer, and then operate the recipe function again.</li> </ol>  |
| 357        | The specified drive of PLC is abnormal                                  | When the file register name is designated and then the recipe function is operated, there is a fault in the PLC drive.                               | <ol style="list-style-type: none"> <li>1. Check the designated PLC drive, and then operate the recipe function again.</li> <li>2. Apply Format PLC memory to the designated PLC drive with the GX Developer, and then operate the recipe function again.</li> </ol>  |
| 358        | File of PLC access failure  | When the file register name is designated and then the recipe function is operated, the PLC file register could not be accessed.                     | <ol style="list-style-type: none"> <li>1. Check the designated PLC drive/ file register name, and then operate the recipe function again (If drive 0 was designated, change to a different drive, and then operate the recipe function again).</li> <li>2. Check whether the memory card is write-protected, and then operate the recipe function again.</li> </ol>  |
| 359        | Processing is from another peripheral device                            | When the file register name is designated and then the recipe function is operated, other peripheral devices begin processing for the file register. | Wait until the peripheral devices finish operating, and then operate the recipe function again.  |
| 360        | Division error due to divisor of 0                                      | Divisor 0 occurred in the data operation formula   | Reconsider the data operation formula to avoid the divisor of 0  |
| 370        | Contradiction in magnitude relationship of upper and lower limit values | Upper and lower limit values have been set as [upper limit $\leq$ lower limit]   | Check the upper and lower limit value setting and correct them to be [upper limit $\geq$ lower limit]  |
| 402        | Communication time-out  | Time-out error occurred during communication   | <ol style="list-style-type: none"> <li>1. Check for any disconnected cable or improperly fitted communication module</li> <li>2. This may occur if the programmable logic controller load is increased while accessing another station. In this case, move the other station's data to the local station's programmable logic controller, and monitor with the local station.</li> <li>3. If the sequence scan is long, insert a COM command.</li> </ol> |
| 407        | Other network accessed by MNET10 module                                 | Access was made to the other network at the time of MELSECNET connection (network system)  | Check the network number in the screen data to avoid access to the other network   |
| 421        | The specification of E71 cannot be written                              | The Ethernet module on the PLC side has been set for write disable.  | Set the PLC side Ethernet module for write enable.   |
| 422        | It is not communicate between the CPU and E71                           | The CPU is faulty or communication cannot be made between the CPU and PLC side Ethernet module.  | Check the CPU for any fault using GX Developer or like. (Check the buffer memory.)   |
| 423        | Information is insufficient in network table                            | The station number set as the screen data does not exist in the Ethernet setting of GT Designer.   | Add the station number set as the screen data to the Ethernet setting of GT Designer. (Use the station number of the PLC side Ethernet module set in the parameter setting of GX Developer.)   |

| Error Code | Error Message   | Definition  | Action  |
|------------|---|---|---|
| 424        | The same bureau is set by GOT and monitor data.         | The station number set on the utility screen of the GOT is the same as the station number set in the Ethernet setting of GT Designer (station number of the PLC side Ethernet module) or the station number set as the screen data. | Check the following data and do not use the same station number.<br>1. Check the station number of the GOT on the utility screen of the GOT.<br>2. Check the station number set as the screen data.<br>3. Check the station number set in the Ethernet setting.<br>(Use the station number of the PLC side Ethernet module set in the parameter setting of GX Developer.) |
| 448        | Devices outside file register and other ranges included | Devices specified are outside file register or buffer memory range of QnACPU  | Set PLC file registers. Also correct monitor devices  |
| 470        | Communication destination faulty                        | During monitoring of the other station via MELSECNET/10, a fault occurred in the corresponding communication station  | Check whether the corresponding communication station has been set correctly in the management station (reconsider the parameters, switch setting, etc.)  |
| 499        | CPU communication error                                 | Other communication error   | Check for any disconnected cable or improperly fitted communication module  |



## 9.3 Precautions for Installation of ROM\_BIOS

## (1) About ROM\_BIOS

ROM\_BIOS is available in two types: for large-sized GOTs (A985GOT, A975GOT, A970GOT, A960GOT) and for medium-sized GOTs (A950GOT, A951GOT, A953GOT, A956GOT) and wide-sized GOT (A956WGOT).

Note the following when installing ROM\_BIOS in the A950GOT, A951GOT, A953GOT, A956GOT or A956WGOT.

- Do not install ROM\_BIOS designed for large-sized GOT in any of the A950GOT, A951GOT, A953GOT, A956GOT and A956WGOT.
- Do not install ROM\_BIOS designated for large-sized GOTs or medium-sized GOTs in the A956WGOT.
- Do not install ROM\_BIOS of a version earlier than the version of ROM\_BIOS installed in the GOT.

For the way of installing ROM\_BIOS, refer to [GT Designer Help Function].

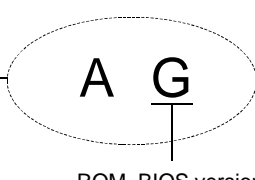
| POINT   |
|---|
| <p>Check the rating plate on the back of the GOT to confirm the version of ROM_BIOS factory-installed in the GOT.</p> <div style="display: flex; justify-content: space-around; align-items: center;"> <div style="border: 1px solid black; padding: 5px; width: 60%;"> <p style="text-align: center;"><b>MITSUBISHI</b></p> <p style="text-align: center;">GRAPHIC OPERATION TERMINAL<br/>MODEL A950GOT-SBD</p> <hr/> <p>IN 24VDC      POWER MAX40W</p> <p>DATE 9904 <b>AG</b></p> <p style="font-size: small;">MITSUBISHI ELECTRIC CORPORATION<br/>MADE IN JAPAN      BD992C032H16</p> <p style="text-align: center;">Rating plate</p> </div> <div style="text-align: center;">  <p>ROM_BIOS version</p> </div> </div> |

## (2) About the messages displayed

- (a) The GOT will display the following messages if you attempt to install ROM\_BIOS that is not compatible with the GOT to be used. Should the following messages appear due to wrong operation you performed, there will be no problems since installation is not executed and ROM\_BIOS is not rewritten.

osが不正です  
Wrong operating system



A few seconds later

osをインストールして下さい  
通信ドライバをインストールして下さい  
Please install operating system  
Please install com. driver

If the above messages have appeared, hold the above screen in that status and install the standard monitor OS, communication driver and so on.

**POINT**

The following message will also appear when you power on your GOT for the first time.

In this case, the message does not relate to the installation of ROM\_BIOS.

Unless you install the standard monitor OS, the following message will appear whenever you start the GOT.

osをインストールして下さい  
通信ドライバをインストールして下さい  
Please install operating system  
Please install com. driver

- (b) The GOT will display the following messages if you attempt to install ROM\_BIOS of a version earlier than the version of ROM\_BIOS installed in the GOT.

Should the following messages appear due to wrong operation you performed, there will be no problems since installation is not executed and ROM\_BIOS is not rewritten.

ROM\_BIOS setup Ver1. 1. 0 [B]

△注意：電源を切らないで下さい。  
リセットボタンを押さないで下さい。

Don't turn off the power supply

Don't push the reset button.

ROM\_BIOS Not Rewriterble.

GOT stopped

Please install operating system.

If the above messages have appeared, hold the above screen in that status and install the standard monitor OS, communication driver and so on.

## 9.4 Troubleshooting in bus connection

If a cause cannot be located by the troubleshooting procedures specified in section 9.2 when the GOT is bus-connected to the PLC CPU, troubleshoot the cause as follows.

### 9.4.1 Locating error positions

#### (1) How to locate error positions:

##### (a) Use of peripheral devices

Using the peripheral devices such as GPP, check what type of the error occurs on the PLC CPU and, based on the error message on the PLC CPU and the check points (See item (2) below), check each module and cable for installation and earthing statuses.

##### (b) Error timing

Check the timing of errors.

- ① An error occurs when the power is turned on or immediately after the PLC is reset:

The error may be detected by the initial processing of the PLC CPU.

In this case, because the faulty module may not be identified, use only an END instruction for the sequence program and remove the modules one by one until the error does not occur.

When the error is eliminated after a specific module has been removed, the module may be causing the error.

- ② An error occurs after a specific operation or several seconds:

The error may occur in the sequence program. Check the error step where the error may occur and the sequence program in that step.

The sequence program can be diagnosed throughout by merely using an END instruction for the sequence program.

- ③ An error occurs when a specific device operates:

The mis-operation may be caused by noise.

Check that any signal line such as bus cable is not laid out too close to the operating device. If the line is too close to the device, separate the line 100 mm or more from the device.

##### (c) Locating the module where an error occurs:

Based on the PLC CPU error codes and special resister information (See item (2)), locate a specific module where an error occurs.

By the method stated above, correct the sequence program or replace the faulty module with a new one, and check whether the error occurs.

If the error continues to occur, it may have another cause.

Referring to section 9.4.2, locate the error position further.

(2) Error messages appearing due to faulty ACPU bus connection and measure against errors

| Error Code | Error Messages    | Check Timing                                | Cause and check point  |  |                   |
|------------|-------------------|---|--|--|-------------------|
|            |                   |   | Error detail   | Remedy   | Corresponding CPU |
| 22         | WDT ERR.          | When an End instruction is executed         | (1) The scanning time exceeds the calculation congestion monitoring time.<br>(2) The scanning time may be extended by waiting for a response from an SP module that is down, and errors may occur simultaneously.  | (1) Use the error history to check whether simultaneous occurrence errors are present.<br>(2) Refer to the SP module down check points.  | ACPU              |
| 31         | UNIT VERIFY ERR.  | When an End instruction is executed         | The information stored in the cards of the module installed in the base module and the communication module of the GOT is different from that read at the initial time.<br>(If an error occurs on a module (vacant) other than that installed in the base module, the mis-operation may be caused by noise.) | Check the faulty module at special registers D9116 to D9123.<br>(1) Check that the module and the cables are connected correctly.<br>(2) Check that the PLC and the GOT are earthed correctly.   |                   |
| 40         | CONTROL_BUS ERR.  | During execution of FROM/TO instruction set | When the FROM/TO instruction is executed, an imprecise response is returned from the special function module (including the GOT).  | Check the faulty module from the error step.<br>(1) Check that the module and the cables are connected correctly.<br>(2) Replace the faulty module with a new one.<br>(3) Check that the PLC and the GOT are earthed correctly.  |                   |
|            |                   | At CPU power ON/<br>At reset                | At the time of initial communication, an imprecise response is returned from the special function module (including the GOT).  | (1) Check that the module and the cables are connected correctly.<br>(2) Because a faulty module cannot be located, remove the modules one by one until no CONTROL_BUS ERR. message appears to indicate the module where the error occurs.<br>(Because the modules are removed, SP. UNIT ERR. message may appear. Stop transmitting the FROM/TO instruction to the applicable module.) |                   |
| 41         | SP. UNIT DOWN     | During execution of FROM/TO instruction set | The special function module was accessed during the execution of a FROM/TO instruction set, but there was no response.   | Check the faulty module from the error step.<br>(1) Check that the module and the cables are connected correctly.<br>(2) Replace the faulty module with a new one.<br>(3) Check that the PLC and the GOT are earthed correctly.  |                   |
|            |                   | At CPU power ON/<br>At reset                | At the time of initial communication, a response is not returned from the special function module (including the GOT).   | (1) Check that the module and the cables are connected correctly.<br>(2) Replace the faulty module with a new one.<br>(3) Check that the PLC and the GOT are earthed correctly.  |                   |
| 43         | I/O INT ERR.      | During interrupt                            | An imprecise interrupt occurs to the PLC CPU.  | (3) Check that the PLC and the GOT are earthed correctly.  |                   |
| 44         | SP. UNIT LAY ERR. | At CPU power ON/<br>At reset                | Too many modules are installed (see the PLC CPU specification).  | (1) Check the number of installed modules.<br>(2) Check the number of extension stages and the I/O slot numbers.   |                   |
| 46         | SP. UNIT ERR.     | During execution of FROM/TO instruction set | The FROM/TO instruction is executed to any module other than the special function module.  | (1) Review the sequence program.<br>(2) Check the number of extension stages and the I/O slot numbers.   |                   |

(3) Error messages appearing due to faulty Q/QnACPU bus connection and measure against errors

| Error Code | Error Messages   | Check Timing   | Cause and check point  |   |   |
|------------|------------------|--|--|---|---|
|            |                  |  | Error detail   | Remedy  | Corresponding CPU   |
| 1310       | I/O INT ERROR.   | During interrupt   | An imprecise interrupt occurs to the PLC CPU.  | (1) Check that the module and the cables are connected correctly.<br>(2) Replace the faulty module and the cables with new ones.<br>(3) Check that the PLC and the GOT are earthed correctly.<br>(4) Check the number of extension stages and the I/O slot numbers.   | QCPU<br>QnACPU  |
| 1401       | SP. UNIT DOWN    | At CPU power ON/<br>At reset/When intelligent function module is accessed. | <ul style="list-style-type: none"> <li>There was no response from the intelligent function module during initial communications stage.</li> <li>The size of the buffer memory of the intelligent function module is abnormal.</li> </ul>   |   | QnACPU  |
|            |                  | At CPU power ON/<br>At reset   | At the time of initial communication, a response is not returned from the special function module (including the GOT).   |   |   |
| 1402       |                  | When an intelligent function module access instruction is executed.        | The intelligent function module was accessed in the program, but there was no response.  |   | QCPU  |
|            |                  | During execution of FROM/TO instruction set                                | The special function module was accessed during the execution of a FROM/TO instruction set, but there was no response.   |   | QnACPU  |
| 1403       |                  | When an End instruction is executed  | <ul style="list-style-type: none"> <li>There was no response from the intelligent function module when the END instruction is executed.</li> <li>An error is detected at the intelligent function module.</li> </ul>   | QCPU  |   |
| 1411       | CONTROL_BUS ERR. | At CPU power ON  | At the time of initial communication, an imprecise response is returned from the special function module (including the GOT).  | (1) Check that the module and the cables are connected correctly.<br>(2) Because a faulty module cannot be located, remove the modules one by one until no CONTROL_BUS ERR. message appears to indicate the module where the error occurs. (Because the modules are removed, SP. UNIT ERR. message may appear. Stop transmitting the FROM/TO instruction to the applicable module.) | QCPU<br>QnACPU  |
| 1412       |                  | During execution of FROM/TO instruction set                                | When the FROM/TO instruction is executed, an imprecise response is returned from the special function module (including the GOT).  |   | Check the faulty module from the error step.<br>(1) Check that the module and the cables are connected correctly.<br>(2) Replace the faulty module with a new one.<br>(3) Check that the PLC and the GOT are earthed correctly. |
| 2000       | UNIT VERIFY ERR. | When an End instruction is executed  | The information stored in the cards of the module installed in the base module and the communication module of the GOT is different from that read at the initial time.<br>(If an error occurs on a module (vacant) other than that installed in the base module, the mis-operation may be caused by noise.) | Check the faulty module at special resistors SD1400 to SD1431.<br>(1) Check that the module and the cables are connected correctly.<br>(2) Check that the PLC and the GOT are earthed correctly.  | QCPU<br>QnACPU  |

| Error Code   | Error Messages    | Check Timing                 | Cause and check point   |   |                   |
|--------------|-------------------|------------------------------|---|---|-------------------|
|              |                   |                              | Error detail  | Remedy  | Corresponding CPU |
| 2100         | SP. UNIT LAY ERR. | At CPU power ON/<br>At reset | (1) In the parameter I/O allocation settings, an intelligent function module was allocated to a location reserved for an I/O module. Or, the opposite has happened.<br>(2) In the parameter I/O allocation settings, a module other than CPU (or nothing) was allocated to a location reserved for a CPU module. Or, the opposite has happened.<br>(3) A general-purpose switch was set to the module with no general-purpose switches. | (1) Reset the parameter I/O allocation according to the status of installation of the intelligent function module.<br>(2) Reset the parameter I/O allocation according to the status of installation of the CPU module.<br>(3) Reset the general-purpose switch settings.<br>(4) Check the number of extension stages and the I/O slot numbers. | QCPU              |
|              |                   |                              | In parameter I/O allocation settings, a special function module was allocated to a location reserved for an I/O module. Or, the opposite has happened.  | (1) Reset the parameter I/O allocation setting to conform with the actual status of the special function modules.<br>(2) Check the number of extension stages and the I/O slot numbers.   | QnACPU            |
| 2101 to 2103 |                   |                              | The modules more than those specified in the PLC CPU specification are installed.   | (1) Check the number of installed modules.<br>(2) Check the number of extension stages and the I/O slot numbers.  | QCPU<br>QnACPU    |
| 2104         |                   |                              | At the MELSECNET/MINI auto refresh parameter settings, the module allocation that was set is different from the actual module models at the station numbers in the link system.   | Reset the parameter MELSECNET/MINI auto refresh unit module allocation setting so that it conforms to the station number of the module that is actually linked.   | QnACPU            |
| 2105         |                   |                              | There are too many special function modules that can use dedicated instructions allocated (number of modules installed).  | Reduce the number of special function modules installed.  |                   |
| 2106         |                   |                              | (1) 5 or more QJ71LP21/BR11 have been installed.<br>(2) 5 or more QJ71E71 (-B2) have been installed.<br>(3) Identical network numbers or station numbers exist in the MELSECNET/10 network system.  | (1) Keep the number to 4 or fewer.<br>(2) Keep the number to 4 or fewer.<br>(3) Check the network numbers and station numbers.  | QCPU              |
| 2107         |                   |                              | Head X/Y set at the parameter I/O allocation settings is also the head X/Y for some other module.   | (1) Reset the parameter I/O allocation setting to conform with the actual status of the special function modules.<br>(2) Check the number of extension stages and the I/O slot numbers.   | QCPU<br>QnACPU    |
| 2108         |                   |                              | (1) Network module A1SJ71LP21, A1SJ71BR11, A1SJ71AP21*, A1SJ71AR21, or A1SJ71AT2*B dedicated for the A2USCPU has been installed.<br>(2) Network module A1SJ71QLP21 or A1SJ71QBR11 dedicated for the Q2AS has been installed.<br>Change the network module to QJ71LP21 or QJ71BR11.  | Change network module to QJ71LP21 or QJ71BR11.  | QCPU              |
|              |                   |                              | AJ71LP21 or AJ71BR11 for use with the AnUCPU network module has been installed.   | Change network module to AJ71QLP21 or AJ71QBR11.  | QnACPU            |
| 2109         |                   |                              | The control system and standby system module configurations are different when a redundant system is in the backup mode.  | Check the module configuration of the standby system.   | Q4ARCPU           |

| Error Code | Error Messages    | Check Timing                             | Cause and check point   |  | Corresponding CPU |
|------------|-------------------|--|---|--|-------------------|
|            |                   |  | Error detail  | Remedy   |                   |
| 2110       | SP. UNIT ERROR.   | When instruction executed                | The FROM/TO instruction is executed to any module other than the special function module.   | (1) Review the sequence program.<br>(2) Replace the faulty module with a new one.  | QCPU<br>QnACPU    |
| 2111       |                   |  | The location designated by link direct device (J□□) is not a network module.  |  |                   |
| 2112       |                   | When instruction executed/<br>STOP → RUN | (1) The location designated by a special function module dedicated instruction is not a special function module.<br>(2) Alternatively, it is not the relevant special function module.  | Review the sequence program.   |                   |
| 2113       |                   |  | No special function module data for simulation purposes has been set in the simulation data.  | Read error individual information, then check and edit the special function module simulation data that corresponds to the numerical value there (program error location).   |                   |
| 2120       | SP. UNIT LAY ERR. | At CPU power ON/<br>At reset             | The location of Q□B and QA1S□B is improper.   | Check the location of the base unit.   | QCPU              |
| 2122       |                   |  | QA1S□B is installed to the basic base unit.   | Install Q□B as the basic base unit.  |                   |
| 2124       |                   |  | (1) A module is installed at 65th or later slot.<br>(2) A module is installed at the slot later than the number of slots specified with base allocation setting.<br>(3) A module is installed at the I/O points later than the 4,096th point.<br>(4) A module installed at the 4,096th point occupies later points. | (1) Remove the module installed at 65th or later slot.<br>(2) Remove the module installed at the slot later than the number of slots specified with base allocation setting.<br>(3) Remove the module installed at the I/O points later than the 4,096th point.<br>(4) Change the last module to a module which does not exceed the 4,096th point. |                   |
| 2125       |                   |  | (1) A module which the QCPU cannot recognize has been installed.<br>(2) There was no response from the intelligent function module.   | (1) Install a module which can be used with the QCPU.<br>(2) Replace the faulty module with a new one.   |                   |
| 5000       | WDT ERROR.        | Always                                   | Program scan time for initial execution type program goes over the initial execution WDT time set in the parameter PC RAS settings.   | Read the error individual information at a peripheral device, check the numerical value (time) there, and shorten scan time if necessary.  | QCPU<br>QnACPU    |
| 5001       |                   |  | Program scan time goes over the WDT value set in the parameter PC RAS settings.   |  |                   |



9.4.2 Further locating error positions

If the function of the PLC cannot be recovered even when the module on which an error occurs is replaced with a new one, the error may be caused by the effect from another module.

Disconnect the extension cables and bus connection cables in order from the modules starting from the module located furthest from the operating position in the system, and check for the status of occurrence of the error each time the cables are disconnected until the error does not occur.

The module or extension cables/bus-connection cables disconnected immediately before the error does not occur are considered to cause the error.

Examples of the ways of further locating error positions are shown below.

Example 1:

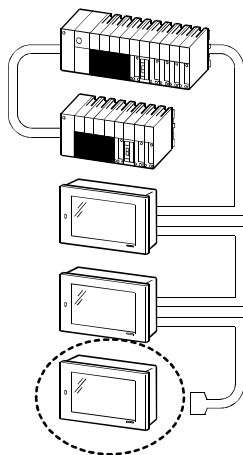
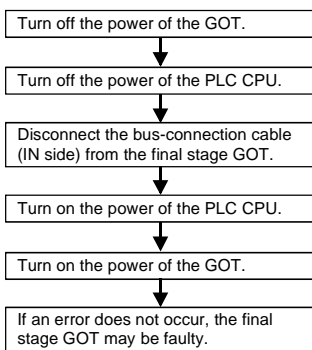

Example 2:

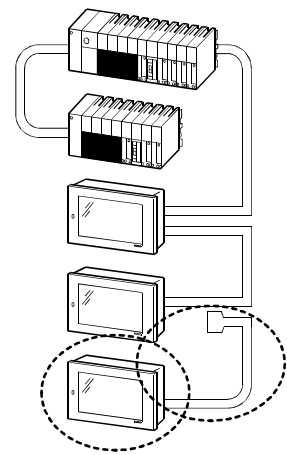
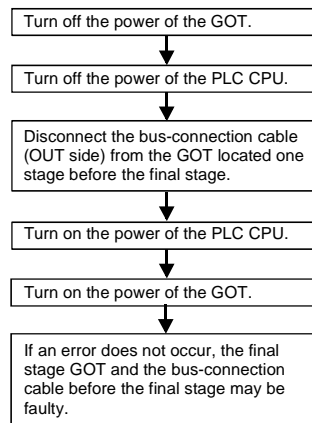

Repeat the examples 1 and 2 above to locate error positions.

| POINT  |
|--|
| <ul style="list-style-type: none"> <li>• When disconnecting the extension base units in order, use only an END instruction for the sequence program, and any error resulting from the sequence program will not occur, and the status of occurrence of errors will be obtained easily.</li> <li>• When the frequency of occurrence of an error is low, check the error by taking a rather long time with the modules disconnected.</li> <li>• The checks stated above are effective to locate a noise invading route when the mis-operation is caused by noise.</li> </ul> |

9.4.3 Specific example of troubleshooting

An example of troubleshooting the system which is used when an error occurs on the PLC CPU is shown below.

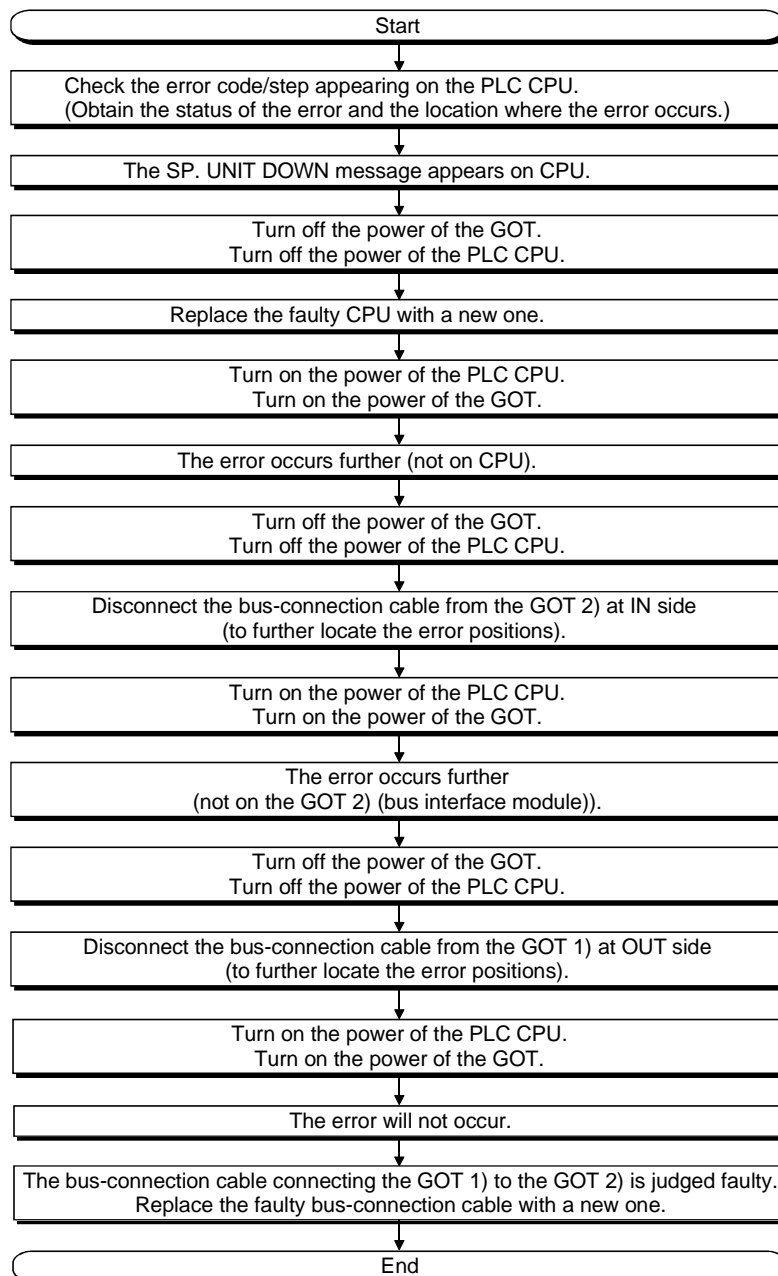
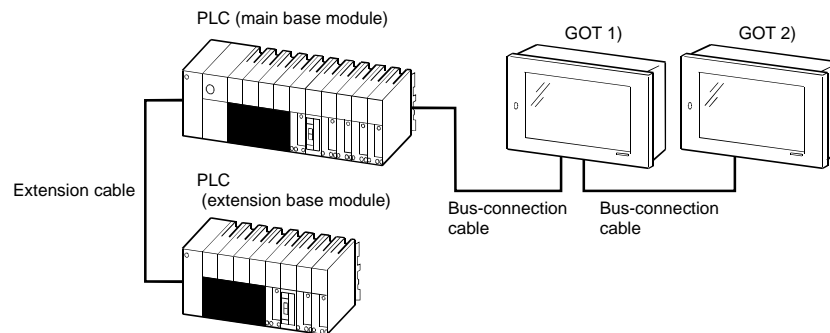

9.5 Troubleshooting for monitoring

The following describes the corrective action when the GOT monitoring screen is blank.

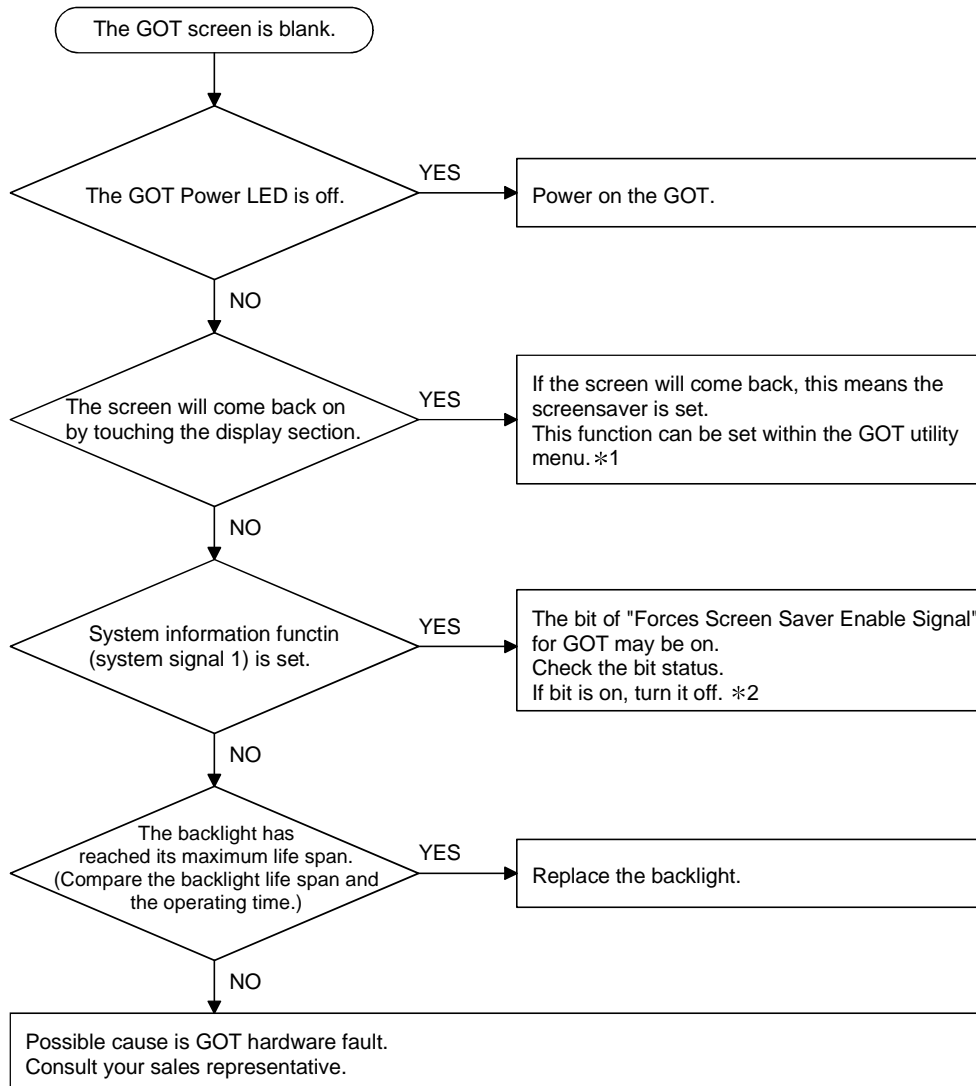

\*1 Refer to GOT-A900 Series Operating Manual (GT Works Versio5/GT Designer Versio5 compatible Extended • Option Functions Manual), for utility menu.

\*2 Refer to GT Designer help function, for details of Forced Screen Saver Enable signal.



APPENDICES

Appendix1 Outline Dimension Drawings

1) Outline dimension drawing of the A95\*GOT

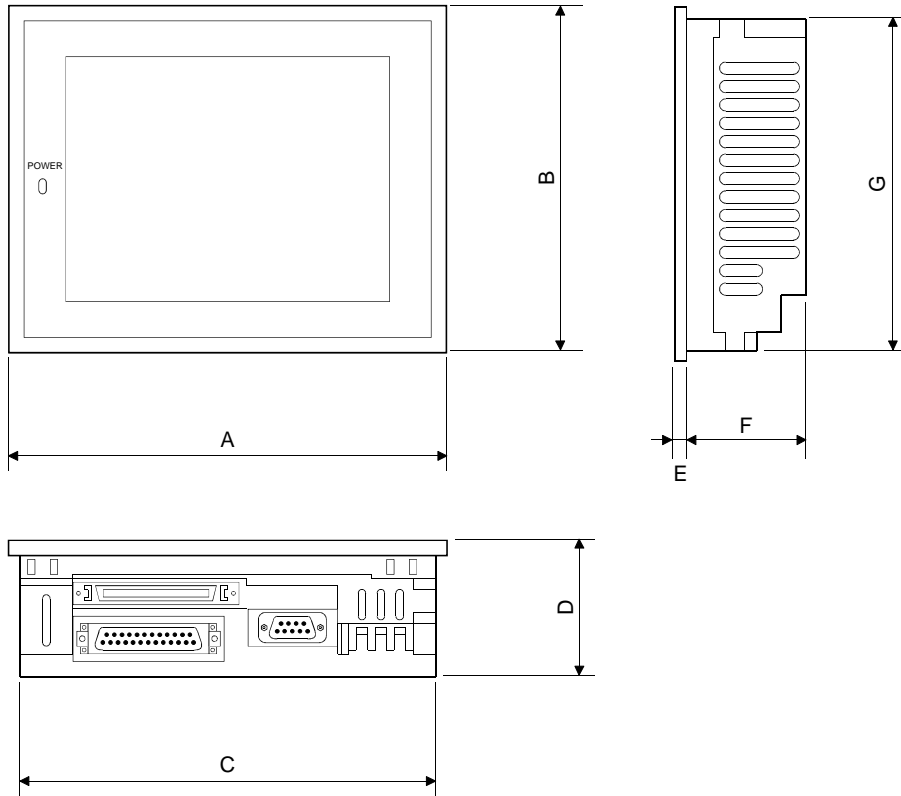

Unit (mm (inch))

| Type code   | A               | B             | C               | D            | E           | F            | G             |
|-------------|-----------------|---------------|-----------------|--------------|-------------|--------------|---------------|
| A95*GOT-TBD | 164.5<br>(6.48) | 136<br>(5.35) | 155.5<br>(6.12) | 65<br>(2.56) | 6<br>(0.24) | 59<br>(2.32) | 123<br>(4.84) |
| A95*GOT-SBD | 164.5           | 136           | 155.5           | 57           | 6           | 51           | 123           |
| A95*GOT-LBD | (6.48)          | (5.35)        | (6.12)          | (2.24)       | (0.24)      | (2.01)       | (4.84)        |

2) Outline dimension drawing of the A956WGOT

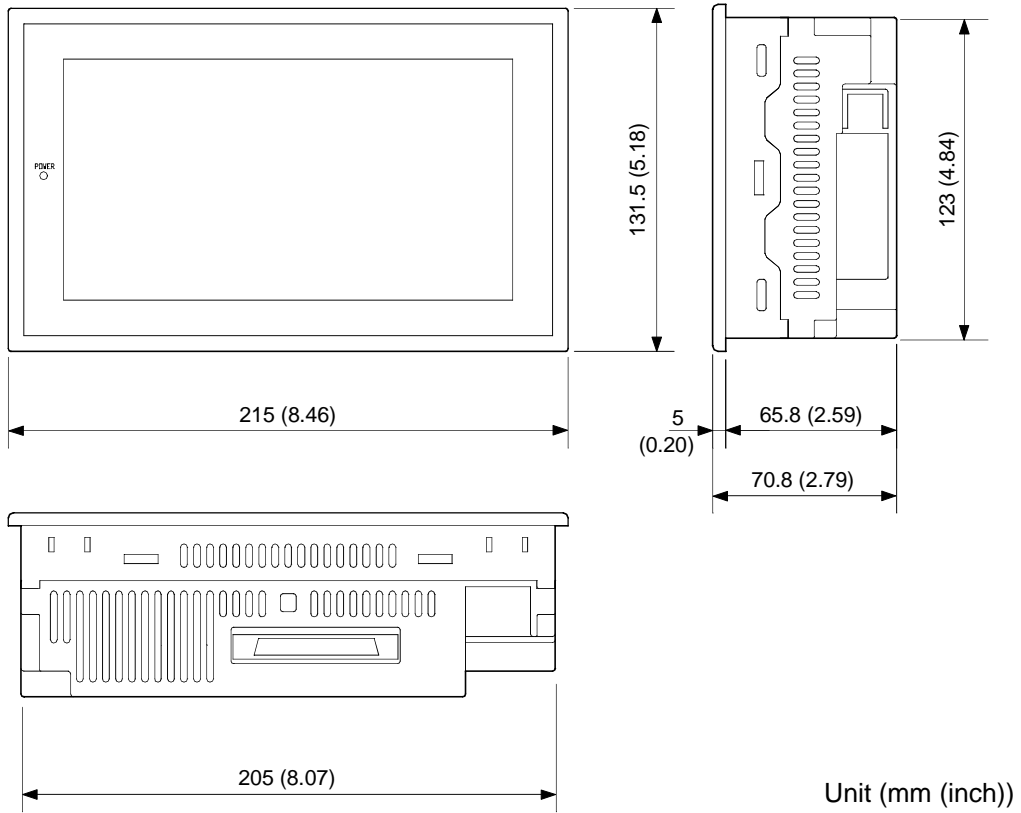

Appendix2 Depth at the Time of Communication Module Loading (A956GOT/A956WGOT Only)

- (1) When A9GT-50WQBUISS is used

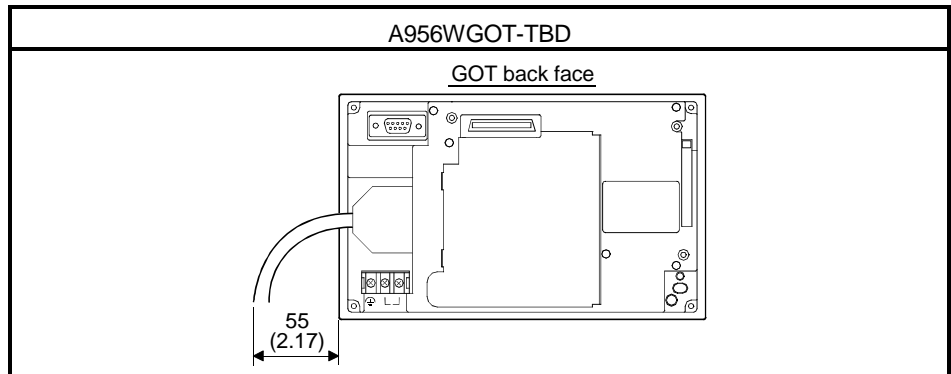

- (2) When A9GT-50WBUSS is used

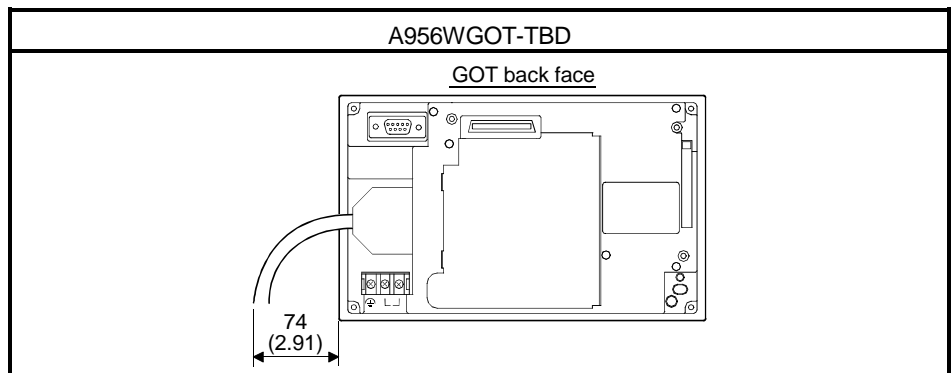

- (3) When A9GT-50WRS2/A9GT-50WRS4 is used

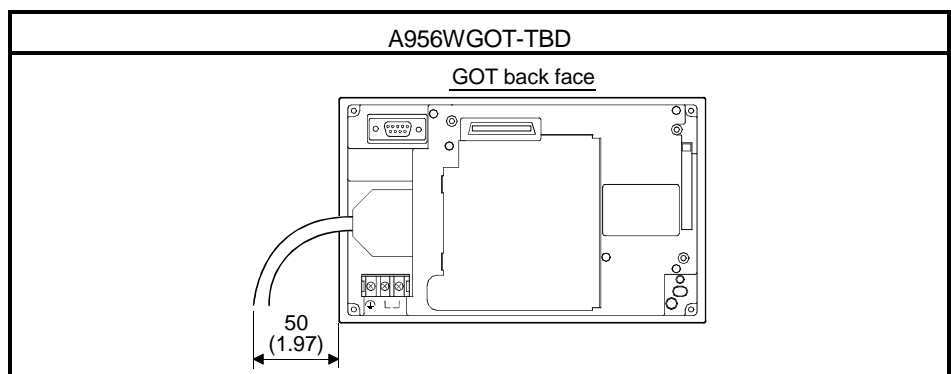

(4) When A9GT-QBUS2SU/A9GT-BUSSU/A9GT-BUS2SU is used

| A956GOT-TBD(-M3)   | A956GOT-SBD/LBD(-M3)   | A956WGOT-TBD   |
|--|--|--|
| <p>GOT side face</p> <p>A9GT-QBUS2SU<br/>A9GT-BUSSU<br/>A9GT-BUS2SU</p> <p>105mm (4.13inch)</p> <p>93mm (3.66inch)</p> | <p>GOT side face</p> <p>A9GT-QBUS2SU<br/>A9GT-BUSSU<br/>A9GT-BUS2SU</p> <p>105mm (4.13inch)</p> <p>85mm (3.35inch)</p> | <p>GOT side face</p> <p>A9GT-QBUS2SU<br/>A9GT-BUSSU<br/>A9GT-BUS2SU</p> <p>105mm (4.13inch)</p> <p>99.8mm (3.93inch)</p> |

(5) When A7GT-BUSS/A7GT-BUS2S is used

| A956GOT-TBD(-M3)  | A956GOT-SBD/LBD(-M3)  |
|---|---|
| <p>GOT side face</p> <p>A7GT-BUSS<br/>A7GT-BUS2S</p> <p>120mm (4.72inch)</p> <p>93mm (3.66inch)</p> | <p>GOT side face</p> <p>A7GT-BUSS<br/>A7GT-BUS2S</p> <p>120mm (4.72inch)</p> <p>85mm (3.35inch)</p> |

(6) When A7GT-J71AP23/A7GT-J71LP23 is used

| A956GOT-TBD(-M3)   | A956GOT-SBD/LBD(-M3)   | A956WGOT-TBD   |
|--|--|--|
| <p>GOT side face</p> <p>A7GT-J71AP23<br/>A7GT-J71LP23</p> <p>*1</p> <p>93mm (3.66inch)</p> | <p>GOT side face</p> <p>A7GT-J71AP23<br/>A7GT-J71LP23</p> <p>*1</p> <p>85mm (3.35inch)</p> | <p>GOT side face</p> <p>A7GT-J71AP23<br/>A7GT-J71LP23</p> <p>*1</p> <p>99.8mm (3.93inch)</p> |

\*1 Determined by the optical fiber cable and connector used.



(7) When A7GT-J71AR23/A7GT-J71BR13 is used

| A956GOT-TBD(-M3)   | A956GOT-SBD/LBD(-M3)   | A956WGOT-TBD   |
|--|--|--|
| <p>GOT side face</p> <p>A7GT-J71AR23<br/>A7GT-J71BR13</p> <p>93mm<br/>(3.66inch)</p> <p>*2</p> | <p>GOT side face</p> <p>A7GT-J71AR23<br/>A7GT-J71BR13</p> <p>85mm<br/>(3.35inch)</p> <p>*2</p> | <p>GOT side face</p> <p>A7GT-J71AR23<br/>A7GT-J71BR13</p> <p>99.8mm<br/>(3.93inch)</p> <p>*2</p> |

\*2 Determined by the coaxial cable and connector used.

(8) When A7GT-J71AT23B is used

| A956GOT-TBD(-M3)  | A956GOT-SBD/LBD(-M3)  | A956WGOT-TBD  |
|---|---|---|
| <p>GOT side face</p> <p>A7GT-J71AT23B</p> <p>115mm<br/>(4.53inch)</p> | <p>GOT side face</p> <p>A7GT-J71AT23B</p> <p>107mm<br/>(4.21inch)</p> | <p>GOT side face</p> <p>A7GT-J71AT23B</p> <p>121.8mm<br/>(4.80inch)</p> |

(9) When A8GT-J61BT13/A8GT-J61BT15 is used

| A956GOT-TBD(-M3)   | A956GOT-SBD/LBD(-M3)   | A956WGOT-TBD  |
|--|--|---|
| <p>GOT side face</p> <p>A8GT-J61BT13<br/>A8GT-J61BT15</p> <p>98mm<br/>(3.86inch)</p> | <p>GOT side face</p> <p>A8GT-J61BT13<br/>A8GT-J61BT15</p> <p>90mm<br/>(3.54inch)</p> | <p>GOT side face</p> <p>A8GT-J61BT13<br/>A8GT-J61AT15</p> <p>104.8mm<br/>(4.13inch)</p> |

(10) When A9GT-J71E71-T is used

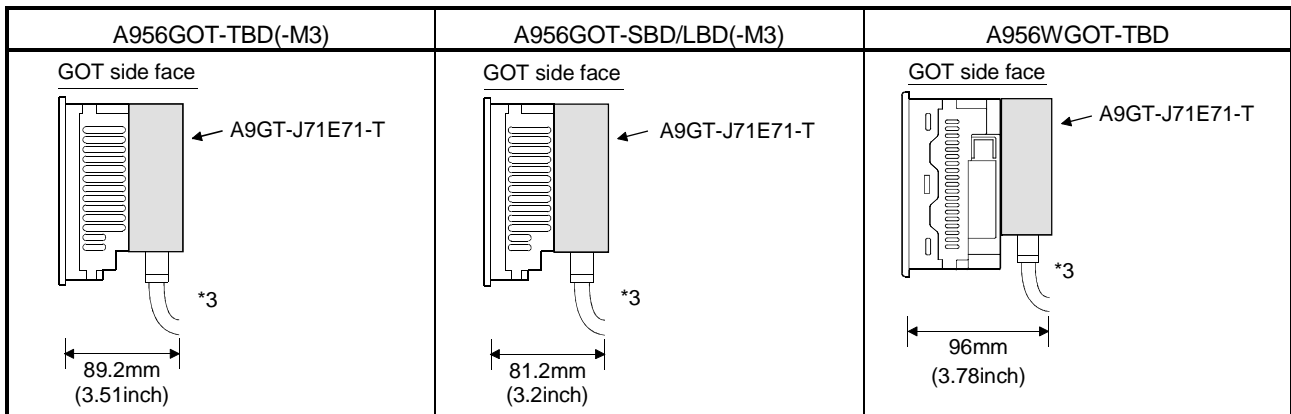

\*3 The bending radius (R1: guideline value) near the connector should be the cable outline × 4 or more.

Appendix3 Outline Dimension Drawings of Bus Connection Cables

| Type           | Connector type      |                     | Cable Diameter [mm] |
|----------------|---------------------|---------------------|---------------------|
|                | GOT side            | PLC side            |                     |
| QC*NB          | (1) in figure below | (4) in figure below | 9.3                 |
| A9GT-QC*BS     | (1) in figure below | (4) in figure below |                     |
| A1SC*B         | (1) in figure below | (1) in figure below | 9.0                 |
| A8GT-C*NB      | (1) in figure below | (3) in figure below | 9.5                 |
| A8GT-C*EXSS *1 | (1) in figure below | (2) in figure below |                     |
| A8GT-C*BS *1   | (1) in figure below | (2) in figure below |                     |

\*1 Provided with the earth cable (1m).

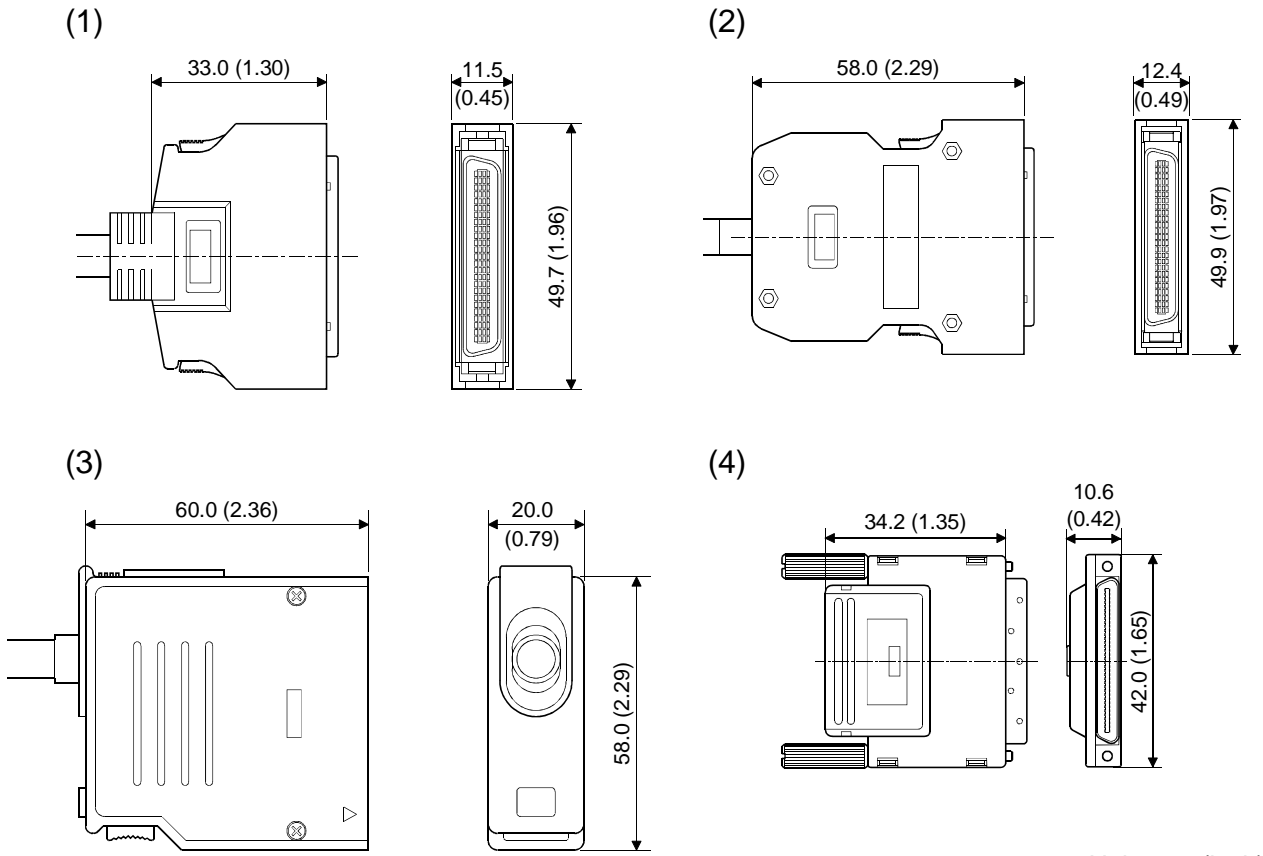

INDEX

[A]  
Attachment (A95\*GOT Only) ..... 6-22

[B]  
Bar Code Reader ..... 6-20

[C]  
Communication Board ..... 6-14  
Communication Module (A956GOT, A956WGOT Only) ..... 6-15  
Compact flash card (A956WGOT Only) ..... 6-12

[D]  
Daily Inspection ..... 7- 2  
Debug Stand..... 6-21  
Depth at the Time of Communication Module Loading (A956GOT, A956WGOT Only)... APP- 3

[E]  
EMC DIRECTIVE ..... 8- 1  
ERROR CODES AND ERROR MESSAGES .. 9- 1  
Error Code and Error Message List..... 9- 2  
External I/O Module ..... 6-19

[H]  
How to Change the Backlight for Liquid Crystal ..... 7- 3

[I]  
Installation method ..... 6- 3

[M]  
Memory Board (A956WGOT Only) ..... 6- 8  
Memory Card Interface Module ..... 6- 9

[N]  
NAMES OF THE PARTS AND THEIR SETTINGS ..... 4- 1  
Notes on Q4ARCPU Duplex System ..... 2- 8

[O]  
Outline Dimension Drawings ..... APP- 1  
Outline Dimension Drawings of Bus Connection Cables..... APP- 6

[P]  
PC card types.....6-10  
PERFORMANCE  
General Specifications .....3- 1  
Performance Specifications .....3- 2  
Power Supply Specifications .....3- 5  
Periodic Inspection.....7- 2  
Printer Interface Module .....6-17  
Printer types .....6-18  
Precautions for Installation of ROM\_BIOS ....9- 6  
Protective Sheet.....6- 7

[R]  
ROUGH PRE-OPERATION PROCEDURE ..5- 1

[S]  
SYSTEM CONFIGURATION  
Overall Configuration .....2- 1  
System Configuration of the GOT .....2- 2  
Component List .....2- 2  
Unusable Conventional Products .....2- 7

[T]  
Troubleshooting in bus connection .....9- 9

[W]  
Wiring method .....6- 4

# WARRANTY

Please confirm the following product warranty details before starting use.

## 1. Gratis Warranty Term and Gratis Warranty Range

If any faults or defects (hereinafter "Failure") found to be the responsibility of Mitsubishi occurs during use of the product within the gratis warranty term, the product shall be repaired at no cost via the dealer or Mitsubishi Service Company. Note that if repairs are required at a site overseas, on a detached island or remote place, expenses to dispatch an engineer shall be charged for.

### [Gratis Warranty Term]

The gratis warranty term of the product shall be for one year after the date of purchase or delivery to a designated place.

Note that after manufacture and shipment from Mitsubishi, the maximum distribution period shall be six (6) months, and the longest gratis warranty term after manufacturing shall be eighteen (18) months. The gratis warranty term of repair parts shall not exceed the gratis warranty term before repairs.

### [Gratis Warranty Range]

- (1) The range shall be limited to normal use within the usage state, usage methods and usage environment, etc., which follow the conditions and precautions, etc., given in the instruction manual, user's manual and caution labels on the product.
- (2) Even within the gratis warranty term, repairs shall be charged for in the following cases.
  1. Failure occurring from inappropriate storage or handling, carelessness or negligence by the user. Failure caused by the user's hardware or software design.
  2. Failure caused by unapproved modifications, etc., to the product by the user.
  3. When the Mitsubishi product is assembled into a user's device, Failure that could have been avoided if functions or structures, judged as necessary in the legal safety measures the user's device is subject to or as necessary by industry standards, had been provided.
  4. Failure that could have been avoided if consumable parts (battery, backlight, fuse, etc.) designated in the instruction manual had been correctly serviced or replaced.
  5. Failure caused by external irresistible forces such as fires or abnormal voltages, and Failure caused by force majeure such as earthquakes, lightning, wind and water damage.
  6. Failure caused by reasons unpredictable by scientific technology standards at time of shipment from Mitsubishi.
  7. Any other failure found not to be the responsibility of Mitsubishi or the user.

## 2. Onerous repair term after discontinuation of production

- (1) Mitsubishi shall accept onerous product repairs for seven (7) years after production of the product is discontinued. Discontinuation of production shall be notified with Mitsubishi Technical Bulletins, etc.
- (2) Product supply (including repair parts) is not possible after production is discontinued.

## 3. Overseas service

Overseas, repairs shall be accepted by Mitsubishi's local overseas FA Center. Note that the repair conditions at each FA Center may differ.

## 4. Exclusion of chance loss and secondary loss from warranty liability

Regardless of the gratis warranty term, Mitsubishi shall not be liable for compensation to damages caused by any cause found not to be the responsibility of Mitsubishi, chance losses, lost profits incurred to the user by Failures of Mitsubishi products, damages and secondary damages caused from special reasons regardless of Mitsubishi's expectations, compensation for accidents, and compensation for damages to products other than Mitsubishi products and other duties.

## 5. Changes in product specifications

The specifications given in the catalogs, manuals or technical documents are subject to change without prior notice.

## 6. Product application

- (1) In using the Mitsubishi MELSEC programmable logic controller, the usage conditions shall be that the application will not lead to a major accident even if any problem or fault should occur in the programmable logic controller device, and that backup and fail-safe functions are systematically provided outside of the device for any problem or fault.
- (2) The Mitsubishi general-purpose programmable logic controller has been designed and manufactured for applications in general industries, etc. Thus, applications in which the public could be affected such as in nuclear power plants and other power plants operated by respective power companies, and applications in which a special quality assurance system is required, such as for Railway companies or National Defense purposes shall be excluded from the programmable logic controller applications.

Note that even with these applications, if the user approves that the application is to be limited and a special quality is not required, application shall be possible.

When considering use in aircraft, medical applications, railways, incineration and fuel devices, manned transport devices, equipment for recreation and amusement, and safety devices, in which human life or assets could be greatly affected and for which a particularly high reliability is required in terms of safety and control system, please consult with Mitsubishi and discuss the required specifications.

# A950GOT/A951GOT/A953GOT/A956GOT

## User's Manual

|                          |                  |
|--------------------------|------------------|
| MODEL                    | A950GOT-U(SHO)-E |
| MODEL CODE               | 13JL92           |
| SH(NA)-080018-E(0202)MEE |                  |

 **mitsubishi electric corporation**

HEAD OFFICE : 1-8-12, OFFICE TOWER Z 14F HARUMI CHUO-KU 104-6212, JAPAN  
NAGOYA WORKS : 1-14, YADA-MINAMI 5, HIGASHI-KU, NAGOYA, JAPAN

When exported from Japan, this manual does not require application to the Ministry of Economy, Trade and Industry for service transaction permission.

Specifications subject to change without notice.